

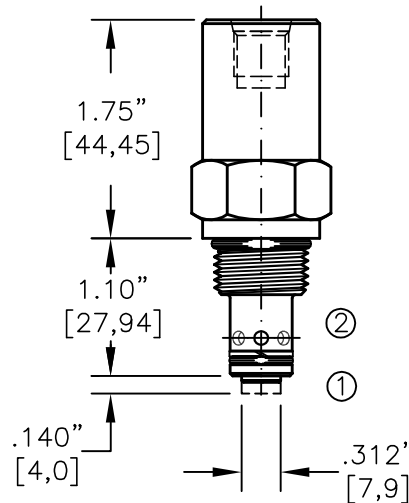

PILOT OPERATED CHECK VALVE POPPET TYPE,
PILOT TO OPEN, 3 TO 1 PILOT RATIO.

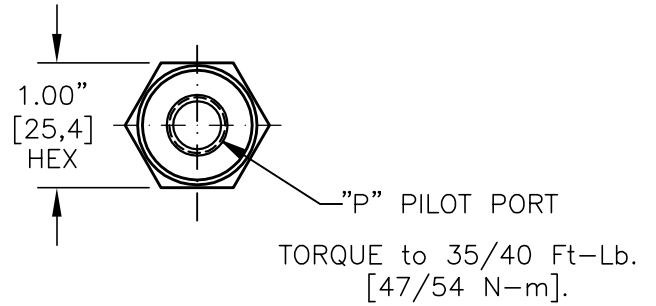
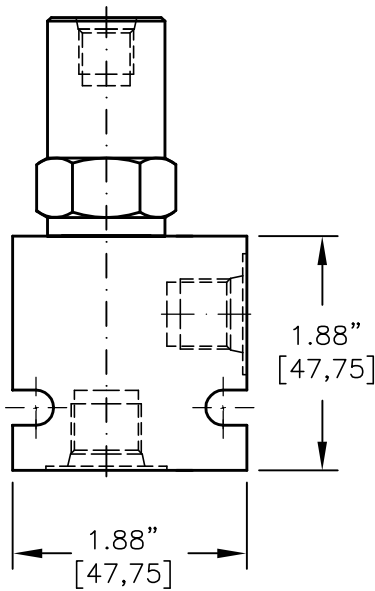
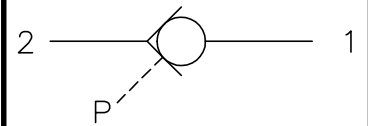

NOTE: CAVITY BOTTOM HOLE MUST ALLOW FOR POPPET EXTENSION (.500 DIA.).
FOR ALUMINUM OR STEEL VALVE HOUSING CONFIGURATIONS SEE PAGE 0-011.1

POCX-08-X-X-4T-XXX

- BASIC
- SIZE
08 = 3/4"-16 UNF
- SEALS
N = BUNA "N"
V = VITON
- PORTS
0 = CARTRIDGE ONLY
02BX = G 1/4" BSPP
06TX = SAE - #6
- "A" - ALUM. HOUSING
"S" - STEEL HOUSING
- CRACK PRESSURE
030 = 30 PSI
060 = 60 PSI
120 = 120 PSI
- "p" PILOT PORT
4T = SAE - #4

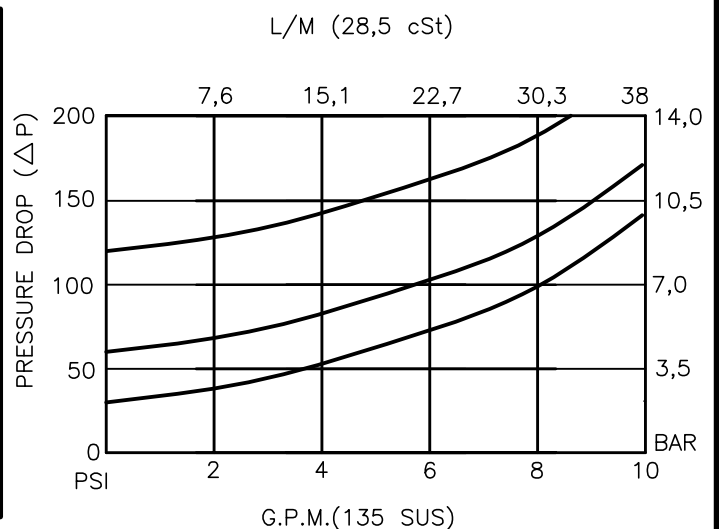



PILOT OPERATED CHECK VALVE POPPET TYPE, PILOT TO OPEN, 3 TO 1 PILOT RATIO

DESCRIPTION

This unit is a SCREW IN, cartridge type, guided poppet, hydraulic pilot operated check valve, for use as a blocking or load holding device for high pressure applications.

OPERATIONS

This valve allows free flow from port 2 to port 1 and blocks flow from port 1 to port 2 or holding a load. Flow will be allowed from port 1 to port 2 when pressure is applied to pilot port "P". This pilot operated check valve has a 3 to 1 pilot ratio, meaning that it takes at least one-third of the load pressure held at port 1 that is required at pilot port "P" to open the valve.

FEATURES AND BENEFITS

Wide selection of bias springs allows flexibility for back-pressure application.

A low friction seal on pilot piston is standard.

All external carbon steel parts are plated for longer life against the elements.

All cartridge valves are 100% functionally tested.

Industry common cavity.

SPECIFICATIONS

OPERATING PRESSURE: 5,000 PSI [350 Bar]

PROOF PRESSURE: 10,000 PSI [700 Bar]

FLOW: 10.0 GPM [38,0 l/m] nominal. See performance chart.

PILOT RATIO: 3 TO 1

INTERNAL LEAKAGE: 5 drops per minute maximum @ 5,000 PSI [350 Bar]

VALVE HOUSINGS: 2500 PSI [175 Bar] = Aluminum - Anodized.

5000 PSI [350 Bar] = Steel - Unplated.

OPERATING TEMPERATURE: -40° to +250° F. [-40° to +120° C.]

OPERATING MEDIA: All general purpose hydraulic fluids such as MIL-H-5606, SAE-#10, SAE-#20, etc.

INSTALLATION: No restrictions.

SEAL KIT: SKN-0821 Buna "N"

SKV-0821 Viton

WEIGHT: .34 lb [.15 kg] cartridge only.

VALVE CAVITY: #C0820, See Page 0-011.0.