

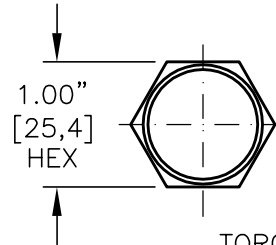

# FLOW DIVIDER/COMBINER TRACTION VALVE

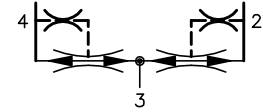

TORQUE to 35/40 Ft-Lb.  
[47/54 N-m].

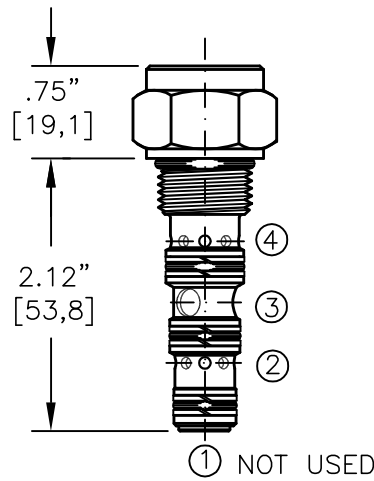
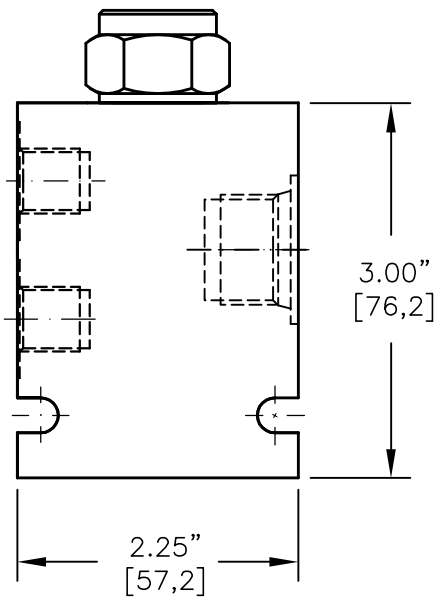

PORT #3 (INLET) IS ONE SIZE LARGER THAN PORTS #2 & #4 (OUTLET).  
FOR ALUMINUM OR STEEL VALVE HOUSING CONFIGURATIONS SEE PAGE 0-041.2

**FDCT-08-X-X-XX**

BASIC	INLET FLOW
SIZE	CODE      FLOW
08 = 3/4"-16 UNF	11      1.0 GPM
SEALS	22      2.0 GPM
N = BUNA "N"	33      3.0 GPM
V = VITON	44      4.0 GPM
PORT#3	66      6.0 GPM
0 = CARTRIDGE ONLY	88      8.0 GPM
03BX = G 3/8" BSPP	
08TX = SAE - #8	
"A" - ALUM. HOUSING	
"S" - STEEL HOUSING	

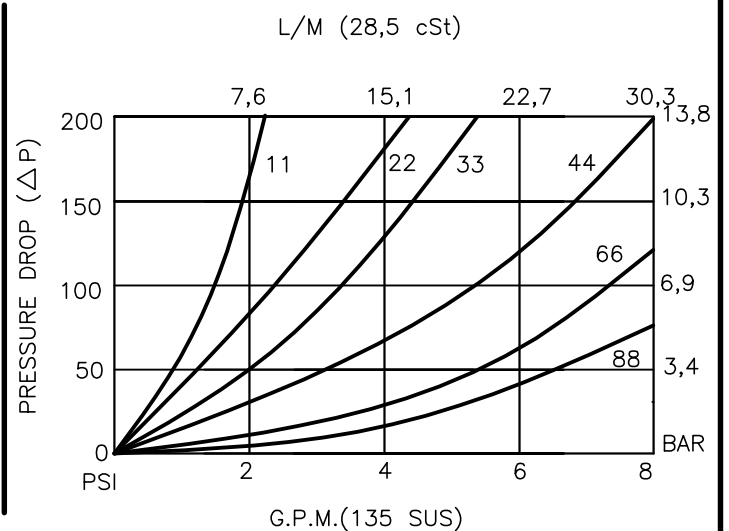



## FLOW DIVIDER/COMBINER TRACTION VALVE

### DESCRIPTION

This unit is a spool type, screw in cartridge style, flow divider/combiner traction valve. This valve is used when hydraulic motors are used as drive motors on each side of a machine.

### OPERATIONS

This valve divides flow from port 3 to ports 2 and 4 and combines flow from ports 2 and 4 to port 3 at the specified flow division regardless of load or system pressure. When the machine turns a corner the valve shifts part of the flow from the inside motor to the outside motor. This allows the wheels to adjust their speed relative to the turn radius to prevent the wheels from skidding.

### FEATURES AND BENEFITS

Equal flow sent to each motor when the machine is driving in a straight line. During a turn, the flow is adjusted between the motors to keep both wheels driving, while adjusting the speed to match the turn. Quiet and stable operation over wide varying flow, pressure and temperature range. All external carbon steel parts are plated for longer life against the elements. All cartridge valves are 100% functionally tested. Industry common cavity.

### SPECIFICATIONS

OPERATING PRESSURE: 5,000 PSI [350 Bar]  
PROOF PRESSURE: 10,000 PSI [700 Bar]  
FLOW: 8.0 GPM [30 l/m] nominal. See performance chart.  
VALVE HOUSINGS: 2500 PSI [175 Bar] = Aluminum - Anodized.  
5000 PSI [350 Bar] = Steel - Unplated.  
OPERATING TEMPERATURE: -40° to +250° F. [-40° to +120° C.]  
OPERATING MEDIA: All general purpose hydraulic fluids such as MIL-H-5606, SAE-#10, SAE-#20, etc.  
INSTALLATION: No restrictions.  
SEAL KIT: SKN-0842 Buna "N".  
SKV-0842 Viton.  
WEIGHT: .24 lb [.11 kg] cartridge only.  
VALVE CAVITY: #C0840, See Page 0-041.2.