

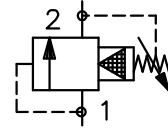

RELIEF VALVE PILOT OPERATED, SLIDING SPOOL

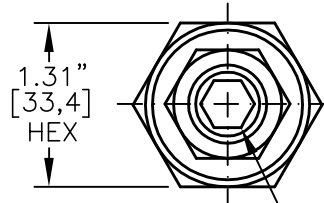

Pat, # 5,546,980

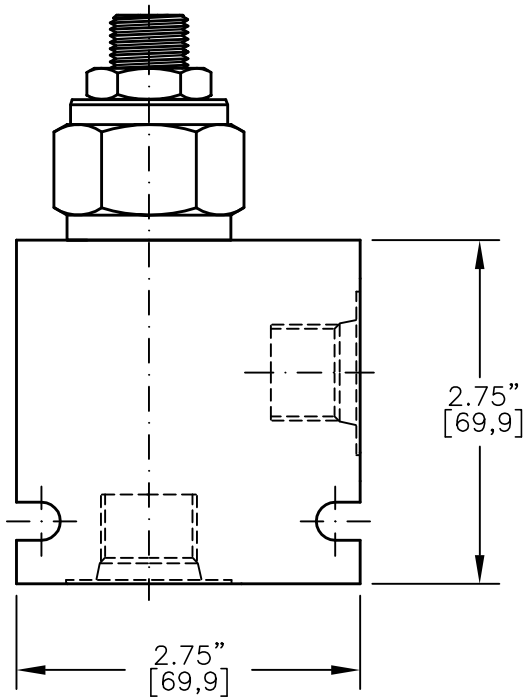

.315" [8,0] HEX.
TORQUE to 70/75 Ft-Lb.
[95/100 N-m]

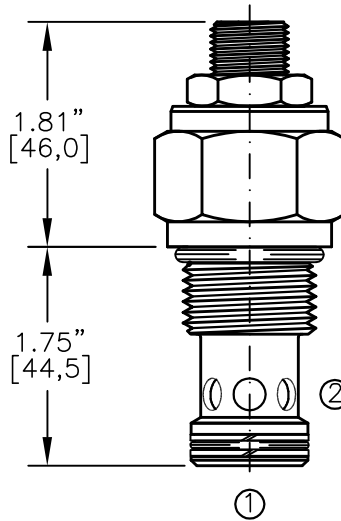

FOR ALUMINUM OR STEEL VALVE HOUSING CONFIGURATIONS SEE PAGE 0-013.1

RVPS-12-X-X-X-XX

- BASIC
- SIZE
12 = 1.062"-12 UNF
- SEALS
N = BUNA "N"
V = VITON
- ADJUSTMENT
S = ADJUSTING SCREW
C = CAPPED
T = TAMPERPROOF
K = HANDKNOB
M = METAL HANDKNOB
- PRESSURE RANGE
15 = 100 TO 1500 PSI
30 = 300 TO 3000 PSI
50 = 500 TO 5000 PSI
- PORTS
0 = CARTRIDGE ONLY
04BX = G 1/2" BSPP
06BX = G 3/4" BSPP
10TX = SAE - #10
12TX = SAE - #12
- "A" - ALUM. HOUSING
"S" - STEEL HOUSING

FOR ADJUSTMENT CONTROL
OPTIONS SEE PAGE 0-050.0

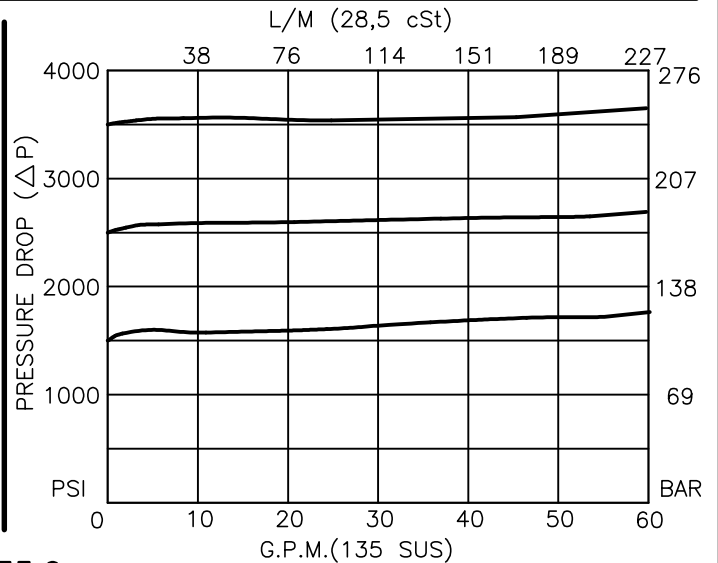



**RELIEF VALVE
PILOT OPERATED, SLIDING SPOOL**

DESCRIPTION

This unit is a PILOT OPERATED, BALANCED SLIDING SPOOL, PRESSURE RELIEF, cartridge valve for accurate and smooth pressure regulation.

OPERATIONS

This valve blocks flow from port 1 to port 2 until sufficient pressure is present at port 1 to force the pilot poppet from its seat thus opening the valve.

This cartridge relief valve offers a smooth transition in response to a load change in a hydraulic circuit.

FEATURES AND BENEFITS

Leakproof screw adjustment.

Pressure in tank port (2) will add to the bias spring setting, and is limited to 2000 PSI.

Adjustment screw can not be backed out of the valve.

Overset protection – pilot spring can not go solid.

Hardened precision fitted spool & cage provides reliable, long life.

A unique self aligning (floating) cage provides very low hysteresis and reliable operation.

All external carbon steel parts are plated for longer life against the elements.

Valve is available with screw, tamperproof, capped and handknob adjustments.

All cartridge valves are 100% functionally tested.

SPECIFICATIONS

OPERATING PRESSURE: 5,000 PSI [350 Bar]

PROOF PRESSURE: 10,000 PSI [700 Bar]

FLOW: 60.0 GPM [227 L/M] nominal. See performance chart.

INTERNAL LEAKAGE: 5 cu.in/min [85 cc/m] @ 95% of crack pressure.

DEFINITION OF CRACK: evident at 0.06 GPM [0.25 LPM]

VALVE HOUSINGS: 2500 PSI [175 Bar] = Aluminum – Anodized.

5000 PSI [350 Bar] = Steel – Unplated.

OPERATING TEMPERATURE: -40° to +250° F. [-40° to +120° C.]

OPERATING MEDIA: All general purpose hydraulic fluids such as MIL-H-5606, SAE-#10, SAE-#20, etc.

INSTALLATION: No restriction.

FILTRATION: 25 microns or better.

SEAL KIT NUMBER: SKN-1222 for Buna "N".

SKV-1222 for Viton.

WEIGHT: 0.63 lb [.25 kg] cartridge only.

VALVE CAVITY: #C1220, See Page 0-013.0.