

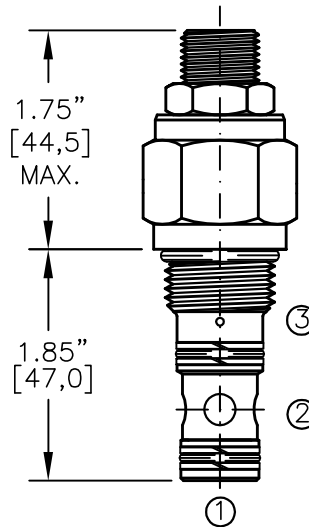

# PRESSURE SEQUENCE VALVE SPOOL TYPE, HI-LO PRESSURE SEQUENCE.

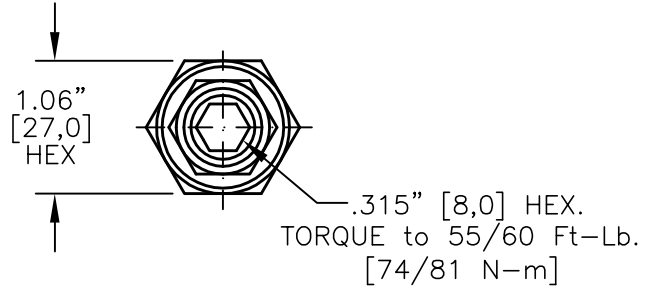
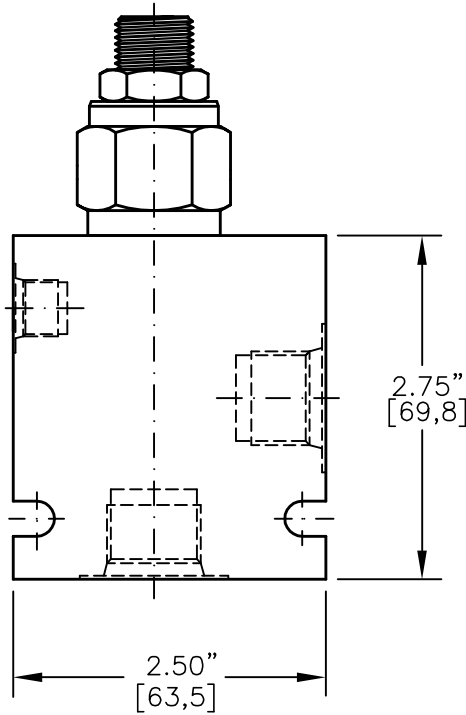
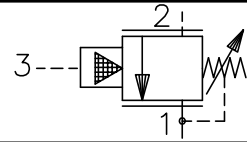

FOR ALUMINUM OR STEEL VALVE HOUSING CONFIGURATIONS SEE PAGE 0-022.1

## HLSS-10-X-X-X-XX

- BASIC
- SIZE  
10 = 7/8"-14 UNF
- SEALS  
N = BUNA "N"  
V = VITON
- ADJUSTMENT  
S = ADJUSTING SCREW  
C = CAPPED  
T = TAMPERPROOF  
K = HANDKNOB  
M = METAL HANDKNOB
- PRESSURE RANGE  
12 = 250 TO 1200 PSI  
20 = 800 TO 2000 PSI  
40 = 2220 TO 4000 PSI
- PORTS  
0 = CARTRIDGE ONLY  
03BX = G 3/8" BSPP  
04BX = G 1/2" BSPP  
08TX = SAE - #8  
10TX = SAE - #10  
"A" - ALUM. HOUSING  
"S" - STEEL HOUSING

FOR ADJUSTMENT CONTROL  
OPTIONS SEE PAGE 0-050.0

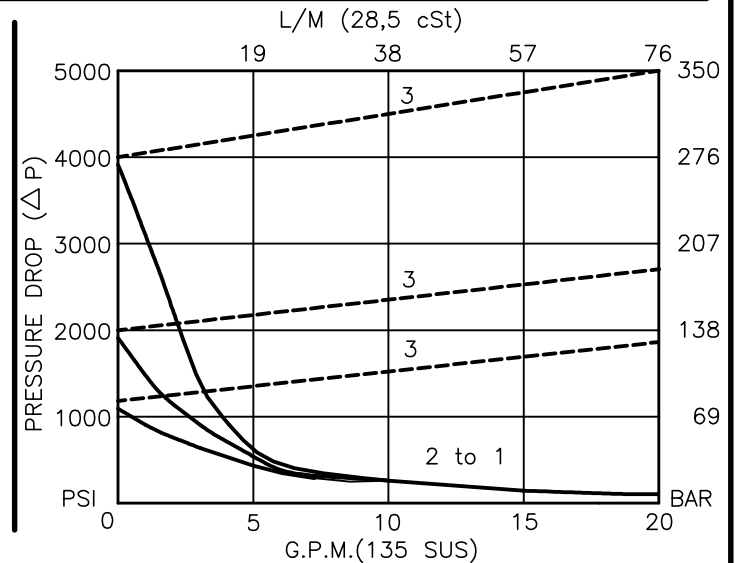



## PRESSURE SEQUENCE VALVE SPOOL TYPE, HI-LO PRESSURE SEQUENCE.

### DESCRIPTION

This unit is a DIRECT ACTING, SCREW IN CARTRIDGE STYLE, SPOOL TYPE, ADJUSTABLE, SOFT SHIFT (shock free), HYDRAULIC HI-LO PRESSURE SEQUENCE VALVE.

### OPERATIONS

This valve blocks flow from port #2 to port #1 until sufficient pressure is present at port #3 to force the differential area spool to shift thus opening the valve very gradually and without any shock. This valve is used in a two pump circuit to load and unload low press. high volume pump, from a high press. low volume pump pressure signal.

### FEATURES AND BENEFITS

Leakproof screw adjustment.  
Adjustment screw can not be backed out of the valve.  
Overset protection – spring can not go solid.  
Hardened precision fitted spool & cage provides reliable, long life.  
A unibody cage construction provides very low hysteresis, dependable and reliable operation.  
All external carbon steel parts are plated for longer life against the elements.  
Valve is available with screw, tamperproof, capped and handknob adjustments.  
All cartridge valves are 100% functionally tested.  
Industry common cavity.

### SPECIFICATIONS

OPERATING PRESSURE: 5,000 PSI [350 Bar]  
PROOF PRESSURE: 10,000 PSI [700 Bar]  
FLOW: 20.0 GPM [76 L/M] nominal. See performance chart.  
INTERNAL LEAKAGE: 5 cu.in./min [85 cc/m] @ 85% of crack pressure.  
DEFINITION OF CRACK: evident at 0.06 GPM [0.25 LPM]  
VALVE HOUSINGS: 2500 PSI [175 Bar] = Aluminum – Anodized.  
5000 PSI [350 Bar] = Steel – Unplated.  
OPERATING TEMPERATURE: -40° to +250° F. [-40° to +120° C.]  
OPERATING MEDIA: All general purpose hydraulic fluids such as MIL-H-5606, SAE-#10, SAE-#20, etc.  
INSTALLATION: No restriction.  
FILTRATION: 25 microns or better.  
SEAL KIT NUMBER: SKN-1027 for buna "N".  
SKV-1027 for viton.  
WEIGHT: 0.46 lb [.21 kg] cartridge only.  
VALVE CAVITY: #C1025, See Page 0-022.0.