

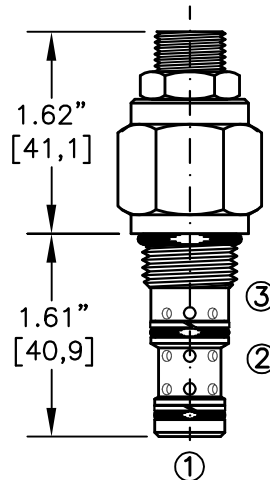

PRESSURE SEQUENCE VALVE PILOT OPERATED, SLIDING SPOOL

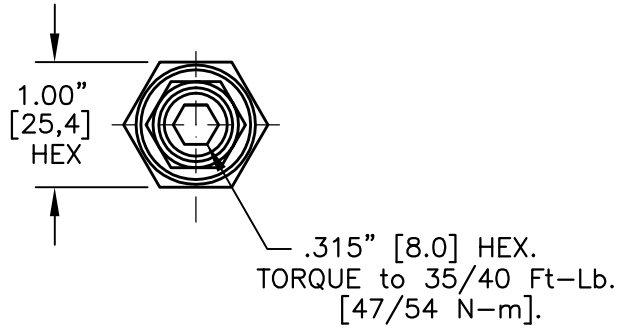
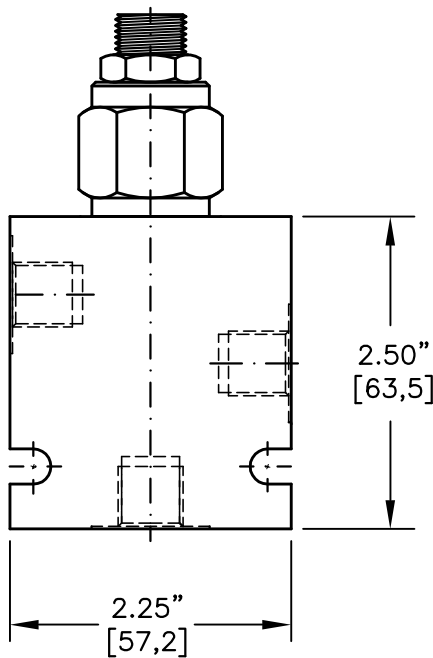
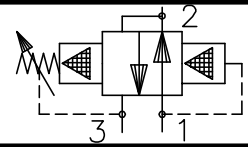

FOR ALUMINUM OR STEEL VALVE HOUSING CONFIGURATIONS SEE PAGE 0-031.1

PSOS-08-X-S-X-XX

- BASIC
- SIZE
08 = 3/4"-16 UNF
- SEALS
N = BUNA "N"
V = VITON
- ADJUSTMENT
S = ADJUSTING SCREW
C = CAPPED
T = TAMPERPROOF
K = HANDKNOB
M = METAL HANDKNOB

- PRESSURE RANGE
15 = 50 TO 1500 PSI
30 = 50 TO 3000 PSI
50 = 50 TO 5000 PSI
- PORTS
0 = CARTRIDGE ONLY
02BX = G 1/4" BSPP
06TX = SAE - #6
"A" - ALUM. HOUSING
"S" - STEEL HOUSING

FOR ADJUSTMENT CONTROL
OPTIONS SEE PAGE 0-050.0

CARTRIDGE ONLY

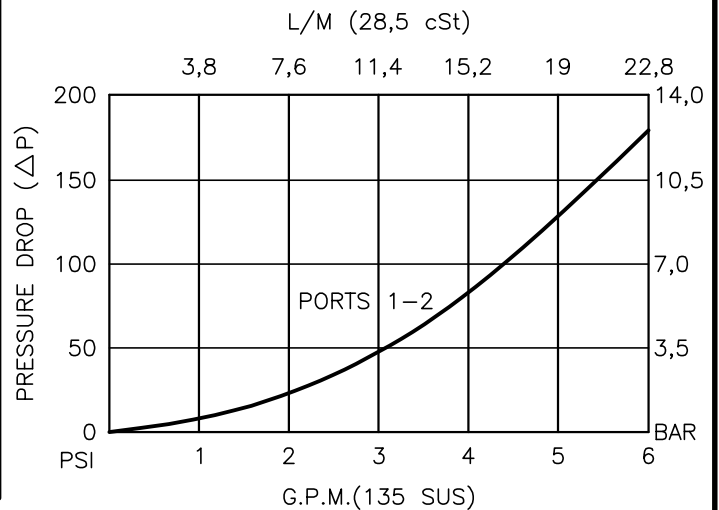



PRESSURE SEQUENCE VALVE PILOT OPERATED, SLIDING SPOOL

DESCRIPTION

This unit is a PILOT OPERATED, SCREW IN CARTRIDGE STYLE, SLIDING SPOOL TYPE, ADJUSTABLE, INTERNAL PILOT, HYDRAULIC PRESSURE SEQUENCE VALVE.

OPERATIONS

This valve is a normally open sequence valve, allowing flow from port 1 to port 2 and blocking flow in port 2 to port 3. When pressure in port 1 exceeds bias spring setting the spool will shift allowing no flow from port 1 to port 2 and pass flow from port 2 to port 3.

FEATURES AND BENEFITS

Leakproof screw adjustment.

Pressure in tank port (3) will add to the bias spring setting, and is limited to 2000 PSI.

Adjustment screw can not be backed out of the valve.

Overset protection—pilot spring can not go solid.

Hardened precision fitted poppet & cage provides reliable, long life.

A unique self aligning (floating) cage provides very low hysteresis and reliable operation.

All external carbon steel parts are plated for longer life against the elements. Valve is available with screw, tamperproof, capped and handknob adjustments.

All cartridge valves are 100% functionally tested.

Industry common cavity.

SPECIFICATIONS

OPERATING PRESSURE: 5,000 PSI [350 Bar]

PROOF PRESSURE: 10,000 PSI [700 Bar]

FLOW: 6.0 GPM [23 L/M] nominal. See performance chart.

INTERNAL LEAKAGE: 5 cu.in./min [.82 cc/m] @ 85% of crack pressure.

DEFINITION OF CRACK: evident at 0.06 GPM [0.25 LPM]

VALVE HOUSINGS: 2500 PSI [175 Bar] = Aluminum - Anodized.

5000 PSI [350 Bar] = Steel - Unplated.

OPERATING TEMPERATURE: -40° to +250° F. [-40° to +120° C.]

OPERATING MEDIA: All general purpose hydraulic fluids such as MIL-H-5606, SAE-#10, SAE-#20, etc.

INSTALLATION: No restriction.

FILTRATION: 25 microns or better.

SEAL KIT NUMBER: SKN-0831 for buna "N".

SKV-0831 for viton.

WEIGHT: 0.30 lb [.14 kg] cartridge only.

VALVE CAVITY: #C0830, See Page 0-031.0.