

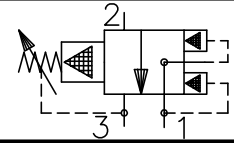

# PRESSURE BREAKER/SEQUENCE VALVE PILOT OPERATED, SLIDING SPOOL

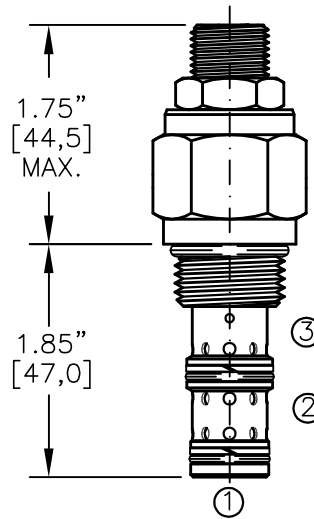

Pat.#5,546,980

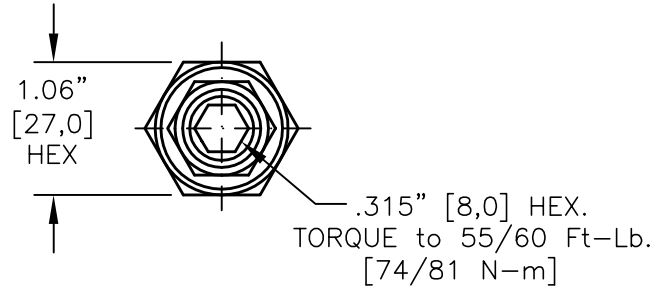
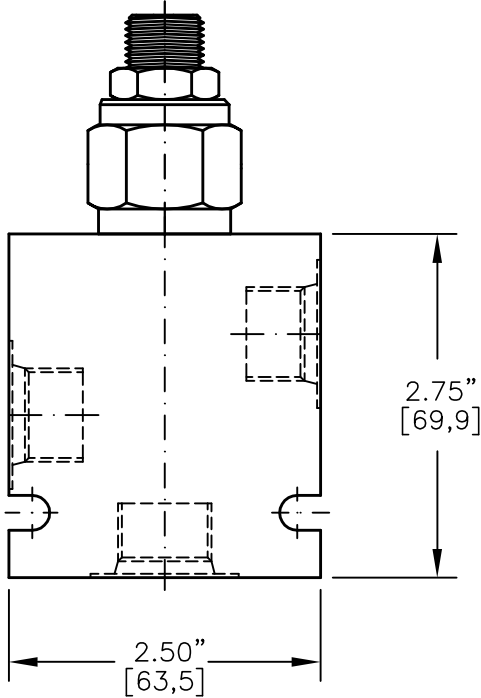

FOR ALUMINUM OR STEEL VALVE HOUSING CONFIGURATIONS SEE PAGE 0-032.1

**BSXS-10-X-X-X-XX**

- BASIC
- SIZE  
10 = 7/8"-14 UNF
- SEALS  
N = BUNA "N"  
V = VITON
- ADJUSTMENT  
S = ADJUSTING SCREW  
C = CAPPED  
T = TAMPERPROOF  
K = HANDKNOB  
M = METAL HANDKNOB
- PRESSURE RANGE  
15 = 50 TO 1500 PSI  
30 = 50 TO 3000 PSI  
50 = 50 TO 5000 PSI
- PORTS  
0 = CARTRIDGE ONLY  
02BX = G 1/4" BSPP  
03BX = G 3/8" BSPP  
06TX = SAE - #6  
08TX = SAE - #8
- "A" - ALUM. HOUSING  
"S" - STEEL HOUSING

FOR ADJUSTMENT CONTROL  
OPTIONS SEE PAGE 0-050.0

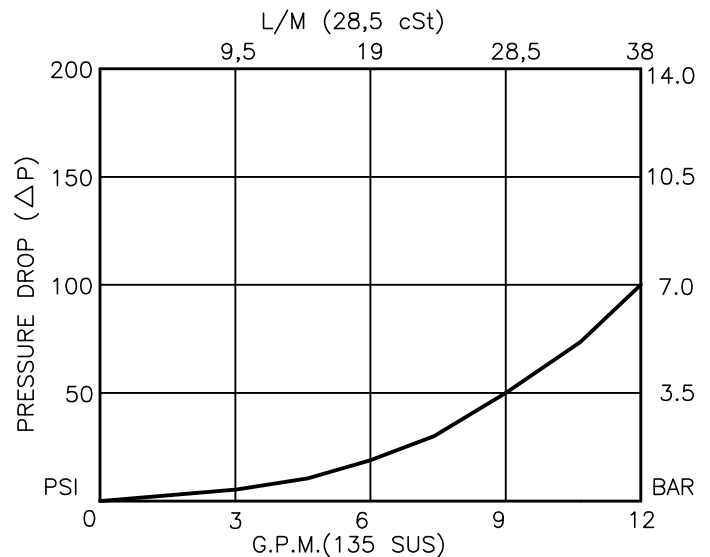



**PRESSURE BREAKER/SEQUENCE VALVE  
PILOT OPERATED, SLIDING SPOOL**

**DESCRIPTION**

This unit is a PILOT OPERATED, SCREW IN CARTRIDGE STYLE, SLIDING SPOOL TYPE, ADJUSTABLE, EXTERNAL PILOT, HYDRAULIC PRESSURE BREAKER/SEQUENCE VALVE.

**OPERATIONS**

This is a normally closed breaker/sequence valve, blocking flow port 2 to port 3. Port 1 is an external pilot port. When pressure in port 1 exceeds spring bias setting the spool will shift and stay shifted allowing flow from port 2 to port 3 until pressure at port 1 is removed. Acts like a circuit breaker in a hydraulic system.

**FEATURES AND BENEFITS**

Leakproof screw adjustment.  
Pressure in tank port (3) will add to the bias spring setting, and is limited to 2000 PSI.  
Adjustment screw can not be backed out of the valve.  
Overset protection—pilot spring can not go solid.  
Hardened precision fitted spool & cage provides reliable, long life.  
A unique self aligning (floating) cage provides very low hysteresis and reliable operation.  
All external carbon steel parts are plated for longer life against the elements.  
Valve is available with screw, tamperproof, capped and handknob adjustments.  
All cartridge valves are 100% functionally tested.  
Industry common cavity.

**SPECIFICATIONS**

OPERATING PRESSURE: 5,000 PSI [350 Bar]  
PROOF PRESSURE: 10,000 PSI [700 Bar]  
FLOW: 12.0 GPM [46 L/M] nominal. See performance chart.  
INTERNAL LEAKAGE: 5 cu.in./min [.82 cc/m] @ 85% of crack pressure.  
DEFINITION OF CRACK: evident at 0.06 GPM [0.25 LPM]  
VALVE HOUSINGS: 2500 PSI [175 Bar] = Aluminum – Anodized.  
5000 PSI [350 Bar] = Steel – Unplated.  
OPERATING TEMPERATURE: -40° to +250° F. [-40° to +120° C.]  
OPERATING MEDIA: All general purpose hydraulic fluids such as MIL-H-5606, SAE-#10, SAE-#20, etc.  
INSTALLATION: No restriction.  
FILTRATION: 25 microns or better.  
SEAL KIT NUMBER: SKV-1033 for unit "N".  
WEIGHT: 0.42 lb [.19 kg] cartridge only.  
VALVE CAVITY: #C1030, See Page 0-032.0.