

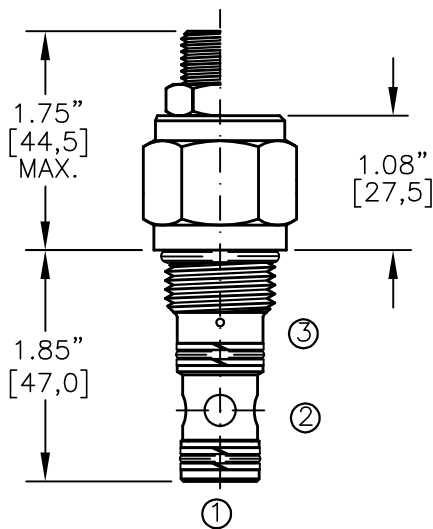

LOGIC CONTROL ELEMENT  
SPOOL TYPE, PILOT TO OPEN, SPOOL "F".

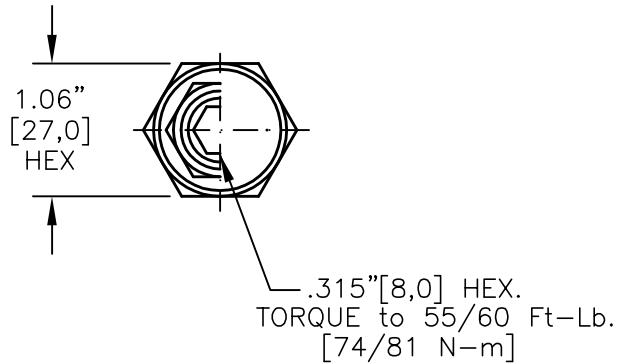
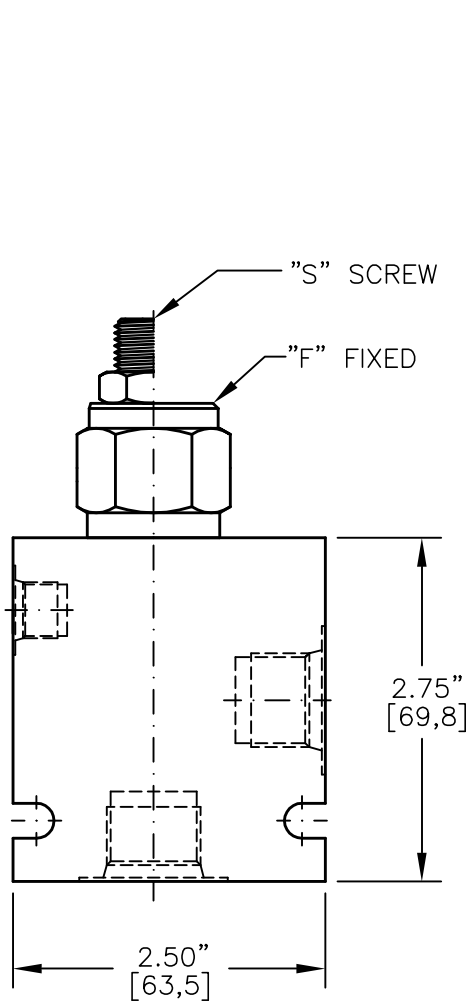
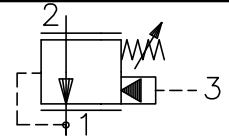

FOR ALUMINUM OR STEEL VALVE HOUSING CONFIGURATIONS SEE PAGE 0-022.1

LCEF-10-X-F-X-X-XXX

- BASIC SIZE
- 10 = 7/8"-14 UNF
- SEALS
- N = BUNA "N"
- V = VITON
- SPOOL
- "F" = SPOOL (PILOT TO OPEN)
- ADJUSTMENT
- F = FIXED (FACTORY SET)
- S = ADJUSTING SCREW
- C = CAPPED
- T = TAMPERPROOF
- K = HANDKNOB
- M = METAL HANDKNOB

- PRESSURE BIAS SPRING
- 070 = 70 PSI (FIXED)
- 100 = 100 PSI (FIXED)
- 160 = 40-160 PSI (ADJ.)
- PORTS
- 0 = CARTRIDGE ONLY
- 03BX = G 3/8" BSPP
- 04BX = G 1/2" BSPP
- 08TX = SAE - #8
- 10TX = SAE - #10
- "A" - ALUM. HOUSING
- "S" - STEEL HOUSING

FOR ADJUSTMENT CONTROL  
OPTIONS SEE PAGE 0-050.0

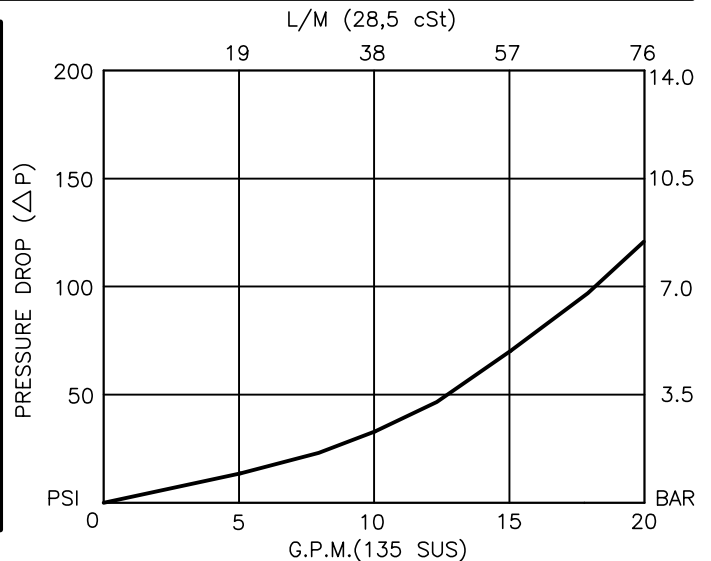



## LOGIC CONTROL ELEMENT

### SPOOL TYPE, PILOT TO OPEN, SPOOL "F".

#### DESCRIPTION

This unit is a DIRECT ACTING, SCREW IN CARTRIDGE STYLE, SPOOL TYPE, HYDRAULIC DIRECTIONAL LOGIC ELEMENT, with multi-functional potential when used with other directional, pressure or flow control devices.

#### OPERATIONS

This valve is normally open from port 2 to port 1 with a spring bias. It will shift to allow full flow from port 2 to port 1 only when there is pressure in port 3. Valve will close when port 3 is opened and will maintain the same pressure plus the bias spring force value. When pressure is present at port 3, it will allow flow from port 2 to port 1, it will close once the pressure and the bias spring force is overcome by pressure in port 1. This is pilot to open directional control logic element.

#### FEATURES AND BENEFITS

Leakproof screw adjustment.

This valve has a fixed or an adjustable bias spring.

Adjustment screw can not be backed out of the valve.

Overset protection – spring can not go solid.

Hardened precision fitted spool & cage provides reliable, long life.

A unibody cage construction provides very low hysteresis and reliable operation.

All external carbon steel parts are plated for longer life against the elements. Valve is available with fixed, screw, tamperproof, capped and handknob adjustments.

All cartridge valves are 100% functionally tested.

Industry common cavity.

#### SPECIFICATIONS

OPERATING PRESSURE: 5,000 PSI [350 Bar]

PROOF PRESSURE: 10,000 PSI [700 Bar]

FLOW: 20.0 GPM [76 L/M] nominal. See performance chart.

INTERNAL LEAKAGE: 5 cu.in./min. [85 cc/m] @ 85% of crack pressure.

DEFINITION OF CRACK: evident at 0.06 GPM [0.25 LPM]

VALVE HOUSINGS: 2500 PSI [175 Bar] = Aluminum – Anodized.

5000 PSI [350 Bar] = Steel – Unplated.

OPERATING TEMPERATURE: -40° to +250° F. [-40° to +120° C.]

OPERATING MEDIA: All general purpose hydraulic fluids such as MIL-H-5606, SAE-#10, SAE-#20, etc.

INSTALLATION: No restriction.

FILTRATION: 25 microns or better.

SEAL KIT NUMBER: SKN-1027 for buna "N".

SKV-1027 for viton.

WEIGHT: 0.46 lb [.21 kg] cartridge only.

VALVE CAVITY: #C1025, See Page 0-022.0.