

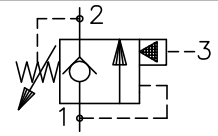

COUNTERBALANCE VALVE POPPET TYPE, FREE REVERSE FLOW & SEALS ON THE PILOT PISTON

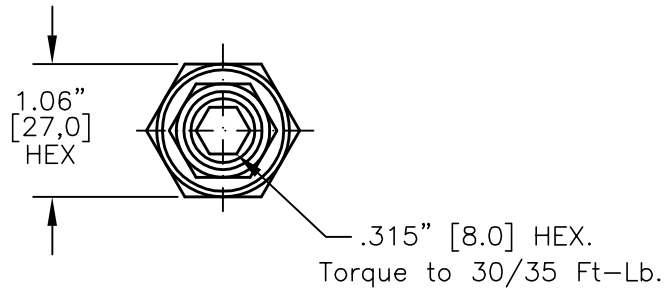

FITS INTO SUN CAVITY # T-11A



Turn screw clockwise to increase the pressure setting.

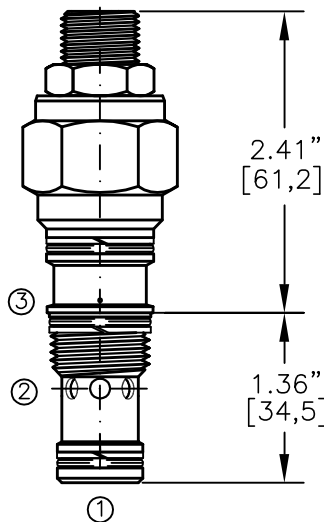

CBPS-20M-X-X-X-XX

- BASIC
- SIZE  
20M=20,0x1,5MM THD.
- SEALS  
N = BUNA "N"  
V = VITON
- ADJUSTMENT  
S = ADJUSTING SCREW  
C = CAPPED  
T = TAMPERPROOF  
K = HANDKNOB  
M = METAL HANDKNOB

- PRESSURE RANGE  
15 = 100 TO 1500 PSI  
30 = 300 TO 3000 PSI  
50 = 500 TO 5000 PSI
- PORTS  
0 = CARTRIDGE ONLY

FOR ADJUSTMENT CONTROL OPTIONS SEE PAGE 0-050.0

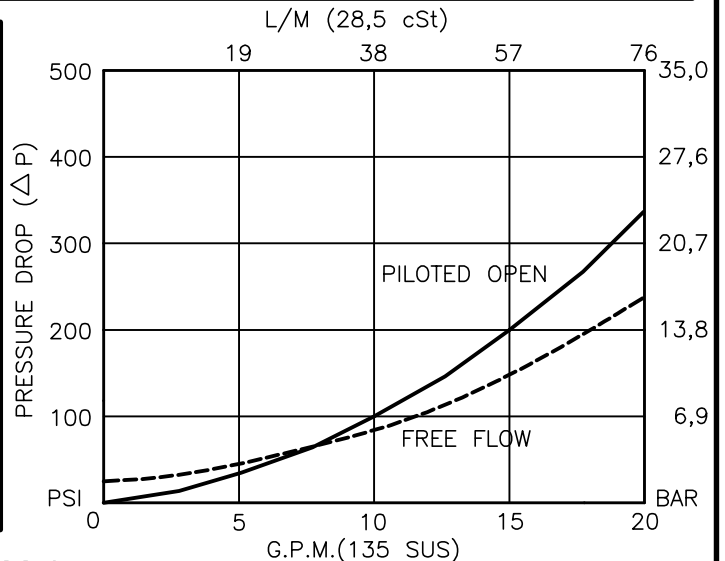



## COUNTERBALANCE VALVE POPPET TYPE, FREE REVERSE FLOW & SEALS ON THE PILOT PISTON.

### DESCRIPTION

This unit is a DIRECT ACTING, SCREW IN CARTRIDGE STYLE, POPPET TYPE, ADJUSTABLE, PILOT ASSISTED, HYDRAULIC COUNTERBALANCE VALVE.

### OPERATIONS

This valve controls moving load and preventing it from running ahead of the pump, locking the load in any position, it also provides static overload and thermal expansion protection.

This valve is a MODULATING DEVICE that allows free flow from port 2 to port 1 and then blocks reverse flow until a pilot pressure INVERSELY PROPORTIONAL to the load pressure is sensed at port 3 modulating out flow from port 1 to port 2.

### FEATURES AND BENEFITS

Leakproof screw adjustment.

Adjustment screw can not be backed out of the valve.

Overset protection – spring can not go solid.

Hardened precision fitted poppet & cage provides reliable, long life.

A unibody adapter cage construction provides very reliable operation.

Seals on the pilot piston assures no flow of fluid between port #2 and port #3.

All external carbon steel parts are plated for longer life against the elements. Valve is available with screw, tamperproof, capped and handknob adjustments.

All cartridge valves are 100% functionally tested.

Fits in to SUN cavity # T-11A.

### SPECIFICATIONS

OPERATING PRESSURE: 5,000 PSI [350 Bar]

PROOF PRESSURE: 10,000 PSI [700 Bar]

FLOW: 20.0 GPM [76 L/M] nominal. See performance chart.

PILOT RATIO: 4 to 1

INTERNAL LEAKAGE: 5 drops/min @ 90% of crack pressure.

DEFINITION OF CRACK: evident at 0.06 GPM [0.25 LPM]

OPERATING TEMPERATURE: -40° to +250° F. [-40° to +120° C.]

OPERATING MEDIA: All general purpose hydraulic fluids such as MIL-H-5606, SAE-#10, SAE-#20, etc.

INSTALLATION: No restriction.

FILTRATION: 25 microns or better.

SEAL KIT NUMBER: SKN-1029 for buna "N".

SKV-1029 for viton.

WEIGHT: 0.46 lb [.21 kg] cartridge only.

VALVE CAVITY: SUN # T-11A.