

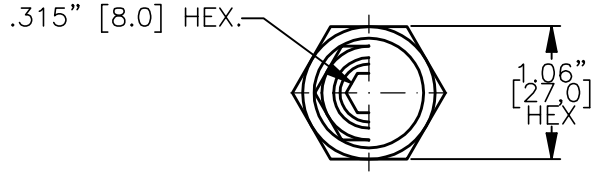

3-WAY DIRECTIONAL CONTROL VALVE SPOOL TYPE, PILOT OPERATED, SPOOL "B".

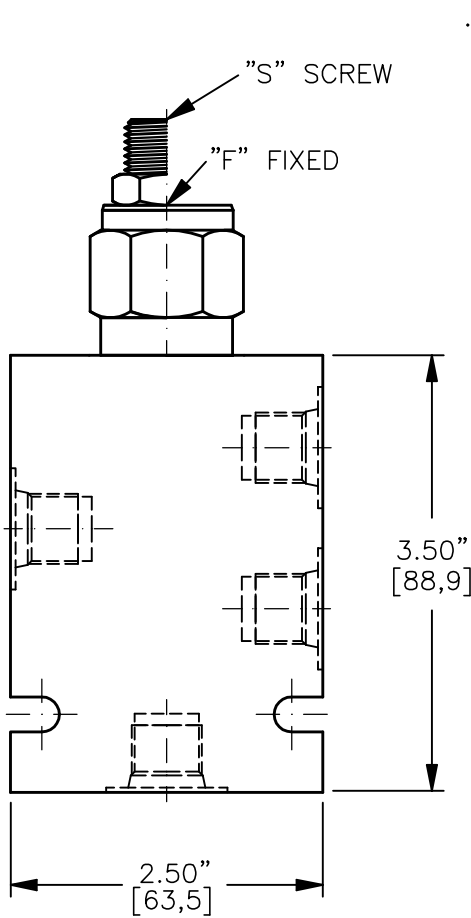

TORQUE to 55/60 Ft-Lb.
[74/81 N-m].

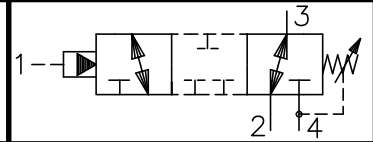
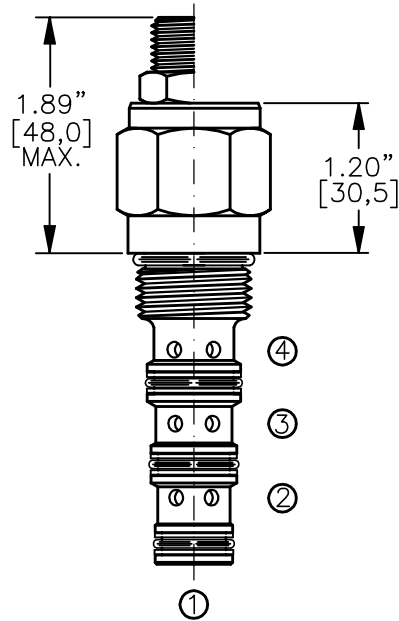

FOR ALUMINUM OR STEEL VALVE HOUSING CONFIGURATIONS SEE PAGE 0-042.1

DCPS-10-X-B-X-X-XXX

- BASIC
- SIZE
10 = 7/8"-14 UNF
- SEALS
N = BUNA "N"
V = VITON
- SPOOL
"B" = SPOOL
- ADJUSTMENT
F = FIXED (FACTORY SET)
S = ADJUSTING SCREW
C = CAPPED
T = TAMPERPROOF
K = HANDKNOB
M = METAL HANDKNOB

- PRESSURE BIAS SPRING
075 = 75 PSI (FIXED)
100 = 100 PSI (FIXED)
200 = 75-200 PSI (ADJ.)

- PORTS
0 = CARTRIDGE ONLY
02BX = G 1/4" BSPP
03BX = G 3/8" BSPP
06TX = SAE - #6
08TX = SAE - #8
- "A" - ALUM. HOUSING
"S" - STEEL HOUSING

FOR ADJUSTMENT CONTROL
OPTIONS SEE PAGE 0-050.0

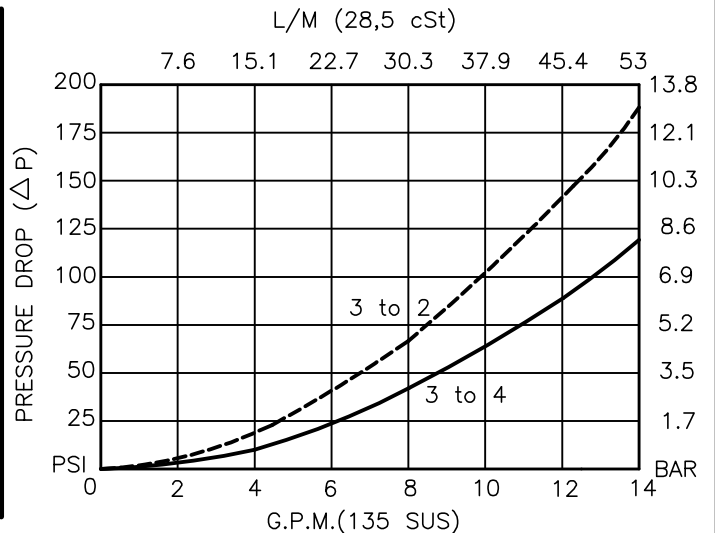



3-WAY DIRECTIONAL CONTROL VALVE SPOOL TYPE, PILOT OPERATED, SPOOL "B".

DESCRIPTION

This unit is a DIRECT ACTING, SCREW IN CARTRIDGE STYLE, SPOOL TYPE, HYDRAULIC 3-WAY DIRECTIONAL CONTROL ELEMENT, requiring remote pilot actuation.

OPERATIONS

This valve allows flow from port 3 to port 2 with a spring biased spool. Port 4 is blocked. The spool will shift when piloted at port 1 with sufficient pressure to overcome the spring bias and allow flow from port 3 to port 4. Spring is vented to port 4. This valve shifts in a closed center position.

FEATURES AND BENEFITS

Leakproof screw adjustment.

This valve has a fixed or an adjustable bias spring.

Adjustment screw can not be backed out of the valve.

Overset protection – spring can not go solid.

Hardened precision fitted spool & cage provides reliable, long life.

A unibody cage construction provides very low hysteresis and reliable operation.

All external carbon steel parts are plated for longer life against the elements. Valve is available with fixed, screw, tamperproof, capped and handknob adjustments.

All cartridge valves are 100% functionally tested.

Industry common cavity.

SPECIFICATIONS

OPERATING PRESSURE: 5,000 PSI [350 Bar]

PROOF PRESSURE: 10,000 PSI [700 Bar]

FLOW: 12.0 GPM [46 L/M] nominal. See performance chart.

INTERNAL LEAKAGE: 5 cu.in./min. [85 cc/m].

DEFINITION OF CRACK: evident at 0.06 GPM [0.25 LPM]

VALVE HOUSINGS: 2500 PSI [175 Bar] = Aluminum – Anodized.

5000 PSI [350 Bar] = Steel – Unplated.

OPERATING TEMPERATURE: -40° to +250° F. [-40° to +120° C.]

OPERATING MEDIA: All general purpose hydraulic fluids such as MIL-H-5606, SAE-#10, SAE-#20, etc.

INSTALLATION: No restriction.

FILTRATION: 25 microns or better.

SEAL KIT NUMBER: SKN-1042 for buna "N".

SKV-1042 for viton.

WEIGHT: 0.46 lb [.21 kg] cartridge only.

VALVE CAVITY: #C1040, See Page 0-042.0.