

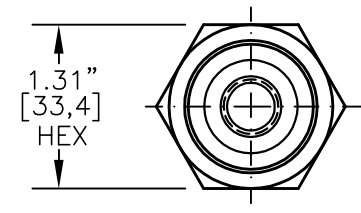

AIR OPERATED DIRECTIONAL CONTROL VALVE THREE-WAY, DIRECT ACTING, SPOOL (3/2)

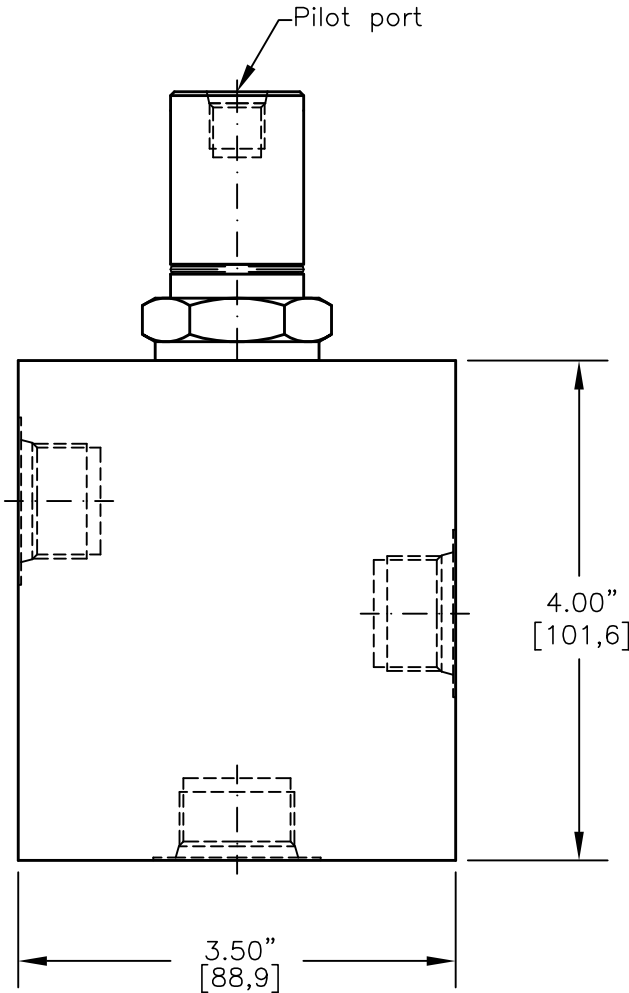

TORQUE to 80/90 Ft-Lb.
[100/120 N-m]

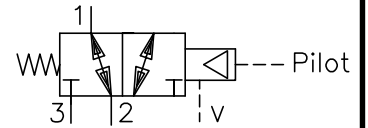
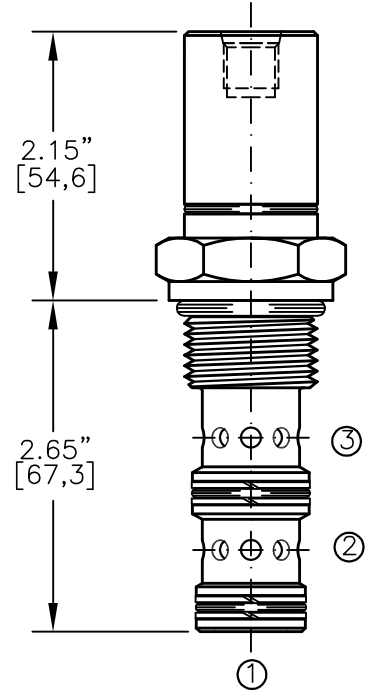

FOR ALUMINUM OR STEEL VALVE HOUSING CONFIGURATIONS SEE PAGE 0-033.1

AODV-12-X-3B-X-XX

- PILOT PORT
 - 1P = 1/8" NPTF
 - 1B = G 1/8" BSPP
 - 4T = SAE - #4
- PORTS
 - 0 = CARTRIDGE ONLY
 - 04BX = G 1/2" BSPP
 - 06BX = G 3/4" BSPP
 - 10TX = SAE - #10
 - 12TX = SAE - #12
- "A" - ALUM. HOUSING
"S" - STEEL HOUSING
- BASIC
- SIZE
 - 12 = 1.062"-12 UNF
- SEALS
 - N = BUNA "N"
 - V = VITON
- SPOOL
 - 3B = "B" SPOOL
 - 2-WAY, 2-POSITION

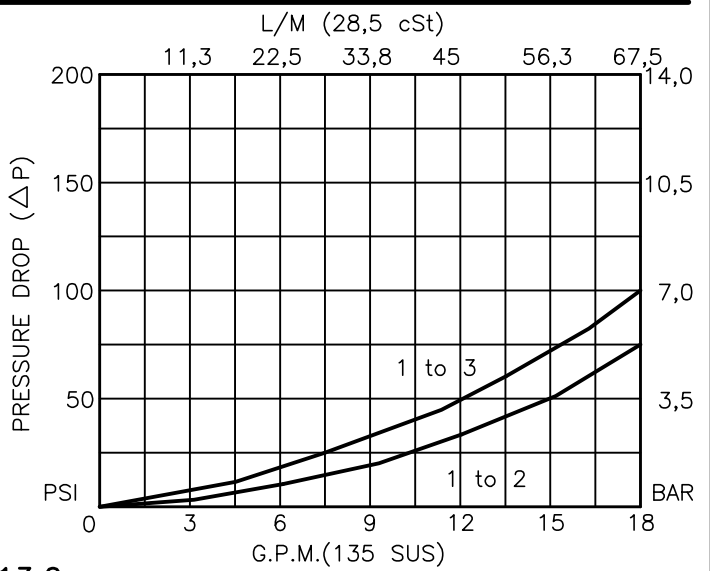



AIR OPERATED, THREE-WAY, DIRECT ACTING, SPOOL TYPE (3/2)

DESCRIPTION

This unit is a THREE-WAY, TWO POSITION, screw-in cartridge style, direct acting spool type, air or hydraulic operated, spring return, hydraulic directional control valve.

OPERATIONS

When pilot piston is not actuated, this valve allows flow between ports 2 to 1 and port 3 is blocked.

When pilot piston is pressurized, the spool in this valve is shifted and allows flow between ports 3 to 1 and port 2 is blocked. This valve shifts in a closed center position.

Port #1 can be pressurized to 18.5 x PILOT PORT pressure.

FEATURES AND BENEFITS

Hardened precision fitted spool & sleeve provides reliable, long life. Corrosion free pilot piston assembly allows this valve to be operated by air or any type of hydraulic fluids.

Pilot piston is isolated from hydraulic fluid with high pressure seals. All external carbon steel parts are plated for longer life against the elements. All cartridge valves are 100% functionally tested.

SPECIFICATIONS

OPERATING PRESSURE: 5,000 PSI [350 Bar]

PROOF PRESSURE: 10,000 PSI [700 Bar]

FLOW: 16.0 GPM [60 l/m] See performance chart.

INTERNAL LEAKAGE: 5 cu.in/min [82 cc/m] @ 5,000 PSI [350 Bar]

VALVE HOUSINGS: 2500 PSI [175 Bar] = Aluminum - Anodized.

5000 PSI [350 Bar] = Steel - Unplated.

OPERATING TEMPERATURE: -40° to +250° F. [-40° to +120° C.]

OPERATING MEDIA: All general purpose hydraulic fluids such as MIL-H-5606, SAE-#10, SAE-#20, etc.

PILOT OPERATING MEDIA: Air or hydraulic fluid.

PILOT PISTON AREA RATIO TO SYSTEM PRESSURE AREA IS: 18.5 to 1.

PILOT OPERATING PRESSURE IS: 50 PSI to 250 PSI air.

SEAL KIT: SKN-1232 Buna "N" 50 PSI to 3000 PSI hydraulic.

SKV-1232 Viton

INSTALLATION: No restrictions.

WEIGHT: 0.68 lb [0,34 kg] cartridge only.

VALVE CAVITY: #C1230, See Page 0-033.0.