

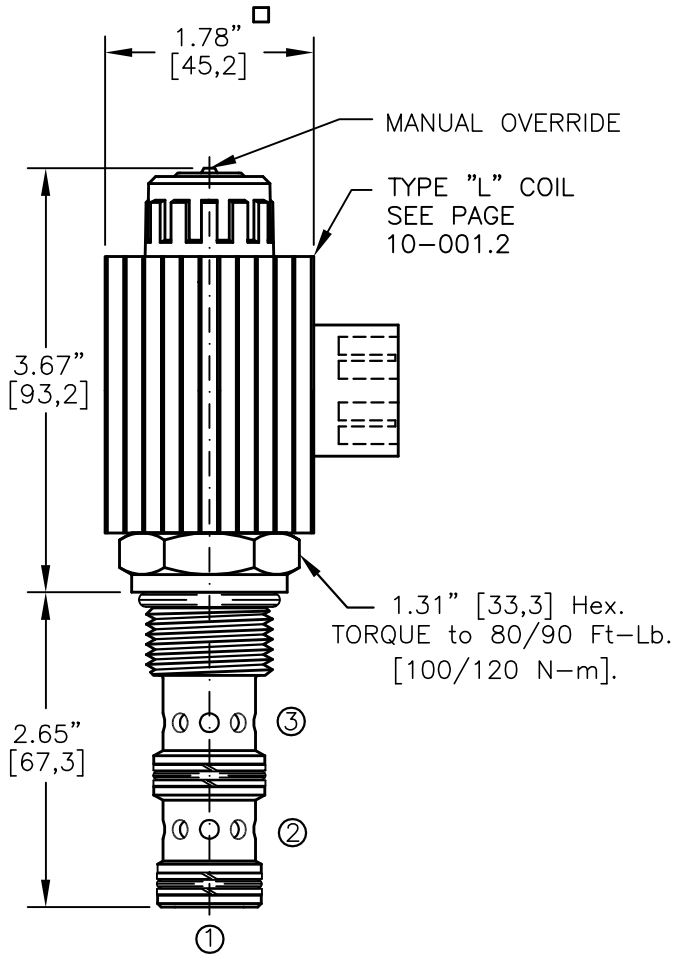

SOLENOID VALVE, 3-WAY, 2-POSITION.  
DIRECT ACTING, SPOOL TYPE (3/2)

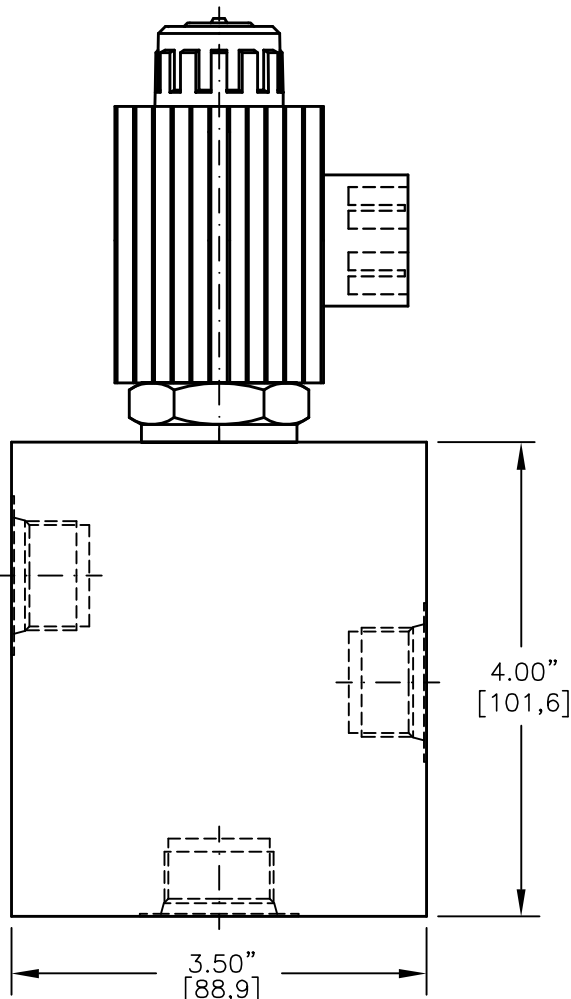
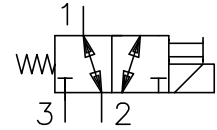

NOTES:

1. FOR ALUMINUM OR STEEL VALVE HOUSING CONFIGURATIONS SEE PAGE 0-033.1
2. SOLENOIDS AVAILABLE WITH DIODES - CONSULT FACTORY.
3. ALL A.C. COILS ARE INTERNALLY A.C. TO D.C. RECTIFIED.
4. FOR SOFT SHIFT SOLENOID VALVE SEE PAGE 10-002.0

EMDV-12-X-3B-X-XXX X

BASIC

SIZE  
12 = 1.062"-12UNF

SEALS  
N = BUNA "N"  
V = VITON

TYPE  
3B = "B" SPOOL  
3-WAY, 2-POSITION

PORTS  
0 = CARTRIDGE ONLY  
04BX = G 1/2" BSPP  
06BX = G 3/4" BSPP  
10TX = SAE - #10  
12TX = SAE - #12

"A" = ALUM. HOUSING  
"S" = STEEL HOUSING

TERMINALS

L=18GA. 24" LEADS  
T=SPADE TERM.  
B=BOLT TERM.  
G=DIN43650  
W=WEATHER-PACK  
D=DEUTSCH-DT04-2P  
M=METRI-PACK CONN.

VOLTAGE	AMPS
12D = 12 VDC	3.00
24D = 24 VDC	1.50
36D = 36 VDC	1.00
48D = 48 VDC	0.75
110D = 110 VDC	0.33
115A = 115 VAC	0.32
230A = 230 VAC	0.16

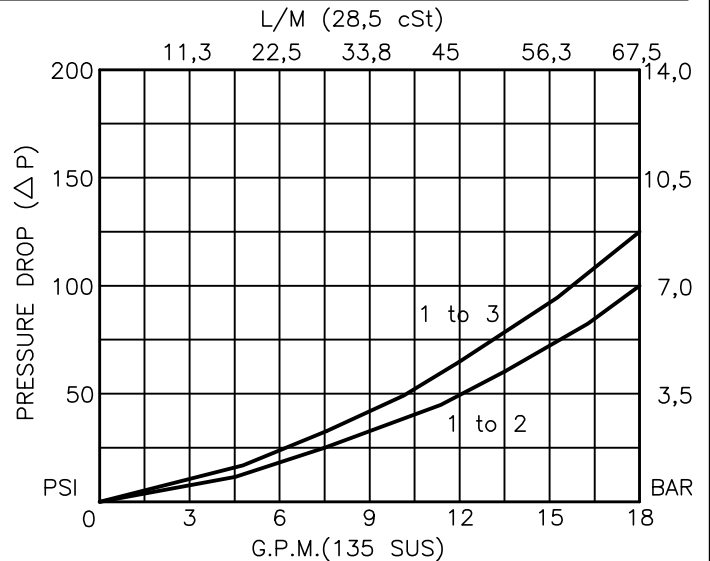



## SOLENOID VALVE 3-WAY, 2-POSITION, DIRECT ACTING, SPOOL TYPE (3/2)

### DESCRIPTION

This unit is a THREE-WAY, TWO POSITION, cartridge type, spool type, direct acting, screw in type, solenoid operated, directional control valve.

### OPERATIONS

When solenoid coil is de-energized, this valve allows flow between ports 1 and 2, port 3 is blocked.

When solenoid coil is energized, the spool in this valve is shifted and allows flow between ports 1 and 3 and port 2 is blocked. The valve shifts in closed position.

Manual Operator Standard: Push in and hold a small plunger on top of the valve with a screw driver or a similar plunger smaller than .188" dia.

### FEATURES AND BENEFITS

Continuous-duty, very low heat rise & waterproof solenoid coil.

Interchangeable solenoid coils & terminations options available.

Hardened precision fitted spool & sleeve provides reliable, long life.

Very efficient, wet-armature solenoid core tube construction.

All external carbon steel parts are plated for longer life against the elements.

All cartridge valves are 100% functionally tested.

### SPECIFICATIONS

OPERATING PRESSURE: 5,000 PSI [350 Bar]

PROOF PRESSURE: 10,000 PSI [700 Bar]

FLOW: 16.0 GPM [60 l/m] See performance chart.

INTERNAL LEAKAGE: 5 cu.in/min [82 cc/m] @ 5,000 PSI [350 Bar]

VALVE HOUSINGS: 2500 PSI [175 Bar] = Aluminum - Anodized.

5000 PSI [350 Bar] = Steel - Unplated.

OPERATING TEMPERATURE: -40° to +250° F. [-40° to +120° C.]

OPERATING MEDIA: All general purpose hydraulic fluids such as MIL-H-5606, SAE-#10, SAE-#20, etc.

RESPONSE TIME: First indication of change in pressure with 100% voltage supplied @ 80% of nominal flow rating.

\* Pull-in: 50 ms

\* Drop-Out: 50 ms

SEAL KIT: SKN-1232 Buna "N"

SKV-1232 Viton

INSTALLATION: No restrictions.

WEIGHT: 2.06 lb [.94 kg] cartridge with coil only.

VALVE CAVITY: #C1230, See Page 0-033.0.