

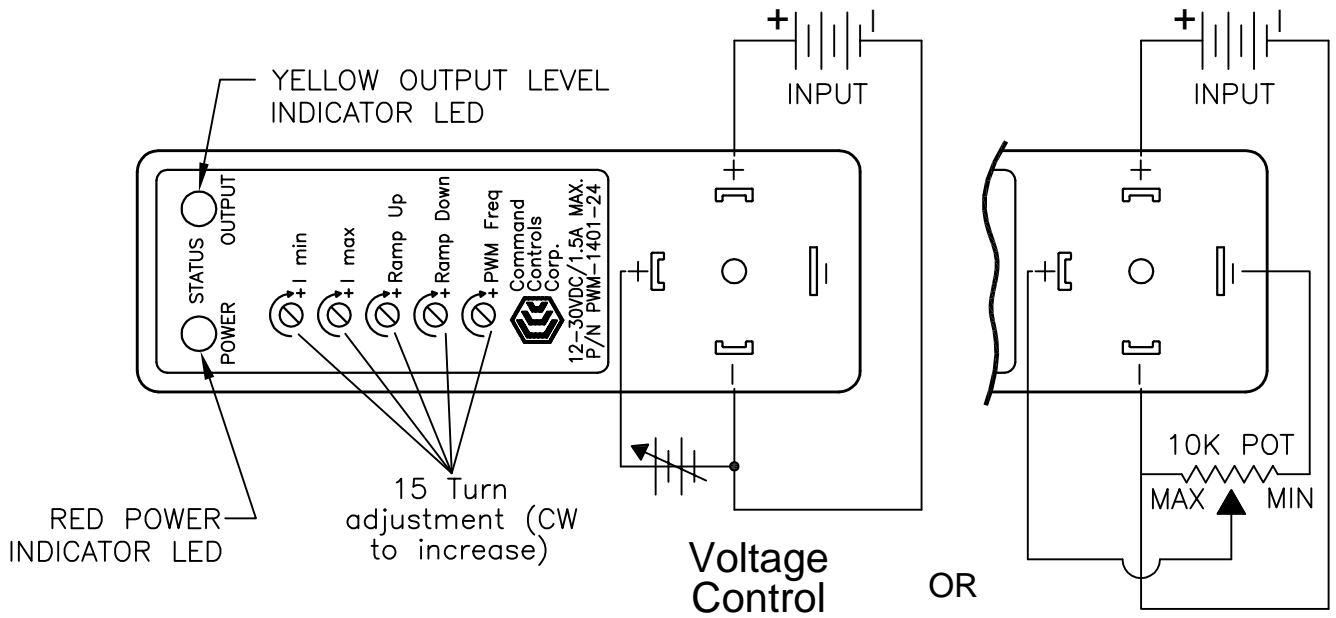

PWM MICRO PROPORTIONAL VALVE DRIVER



YELLOW OUTPUT LEVEL INDICATOR LED

STATUS OUTPUT

POWER

+ I min

+ I max

+ Ramp Up

+ Ramp Down

+ PWM Freq

Command Controls Corp.

12-30VDC/1.5A MAX. P/N PWM-1401-24

RED POWER INDICATOR LED

15 Turn adjustment (CW to increase)

Voltage Control

OR

Potentiometer Control

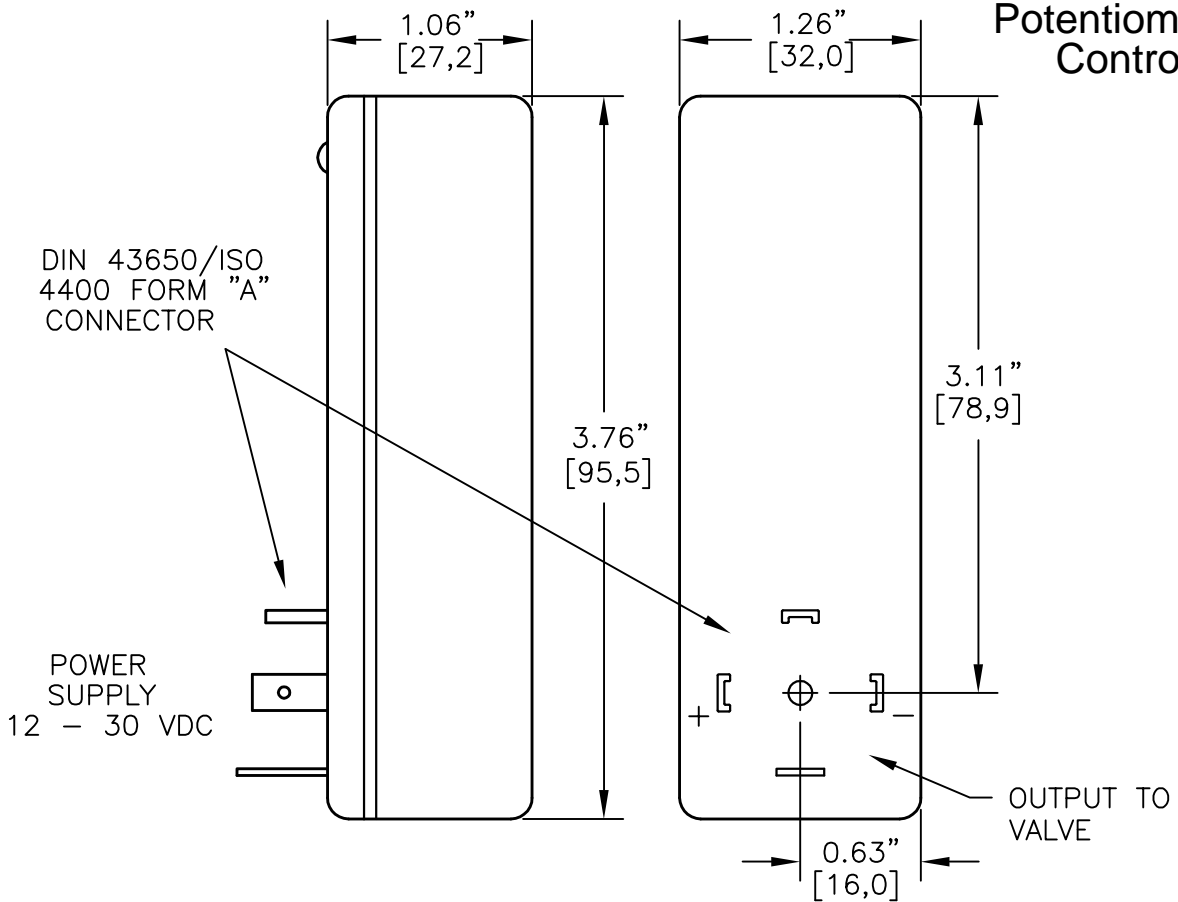

PWM-1401-12..... for use with 12 V.D.C.

PWM-1401-24..... for use with 24 V.D.C.



PWM MICRO PROPORTIONAL VALVE DRIVER

DESCRIPTION:

The Micro Proportional Driver is a coil mounted driver unit used to proportionally control the flow of our solenoid valves.

The electronic circuit for the Micro Proportional Driver is built into an environment resistant miniature enclosure. It incorporates a DIN 43650/ISO 4400 form "A" connector male and female interface, and it is mounted on our coils using a mounting screw.

The case for the driver is made from engineered polymers to resist harsh chemicals, foreign substances, and moisture.

The unit meets NEMA 4 environment standards.

TECHNICAL DATA:

PARAMETER	ALL VERSIONS
SUPPLY VOLTAGE	12 V DC min. – 30 VDC max.
SUPPLY CURRENT	45 mA max. (no load)
INPUT CONTROL SIGNAL	0 – 10 VDC (500 K ohm impedance)
RAMPING UP/DOWN TIME	0.1 – 20 sec. linear (+/- 0.1% / °C)
PWM FREQUENCY	95 – 225 Hz
OUTPUT LEAP TO I MIN	@ 0.2 V or 0.4 mA control (+/- 15%)
OPERATING TEMP.	-25 to 85 °C

PARAMETER	PWM-1401-12	PWM-1401-24
OUTPUT CURRENT @ 25°C Ta		
CONTINUOUS	3.0 Amps max.	1.5 Amps max.
PEAK PULSED (16ms)	17.0A max.	4.7A max.
I MIN. (+/- 20%)	0 – 1.0A max.	0 – 0.5A max.
I MAX. (+/- 20%)	Imin. + 2.0A max.	Imin. + 1.0A max.
REGULATION ΔV	+/- 0.2% / V	
REGULATION ΔT	+/- 0.1% / °C	