

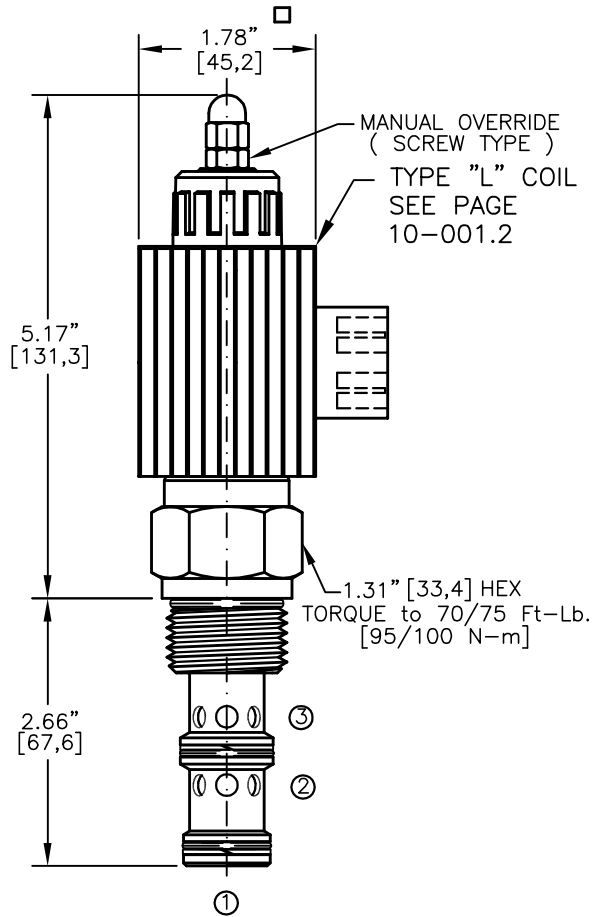

PROPORTIONAL PRESSURE REDUCING/ RELIEVING PILOT OPERATED, SLIDING SPOOL

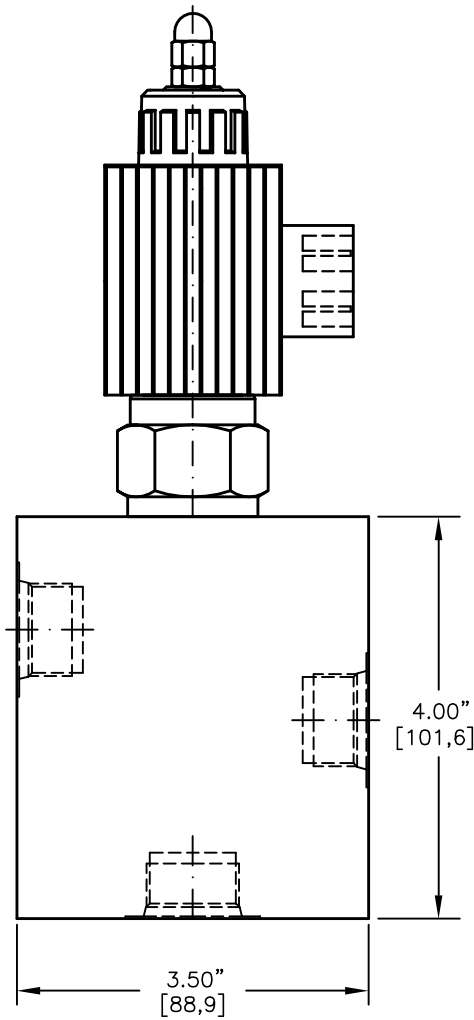
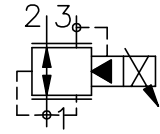

NOTES:

- 1. FOR ALUMINUM OR STEEL VALVE HOUSING CONFIGURATIONS SEE PAGE 0-033.1
- 2. SOLENOIDS AVAILABLE WITH DIODES - CONSULT FACTORY.

EPRS-12-X-XX-X-X-XXX X

BASIC

SIZE
12 = 1.062"-12UNF

SEALS
N = BUNA "N"
V = VITON

REGULATED PRESSURE
15 = 50 TO 1500 PSI
30 = 50 TO 3000 PSI
50 = 50 TO 5000 PSI

TERMINALS

- L=18GA. 24" LEADS
- T=SPADE TERM.
- B=BOLT TERM.
- G=DIN43650
- W=WEATHER-PACK
- D=DEUTSCH-DT04-2P
- M=METRI-PACK CONN.

VOLTAGE AMPS
12D = 12 VDC 3.00
24D = 24 VDC 1.50

ADJUSTMENT OPTIONS
M = MANUAL OVERRIDE

PORTS

- 0 = CARTRIDGE
- 4BX = G 1/2" BSPP
- 6BX = G 3/4" BSPP
- 10TX = SAE - #10
- 12TX = SAE - #12

- "A" - ALUM. HOUSING
- "S" - STEEL HOUSING

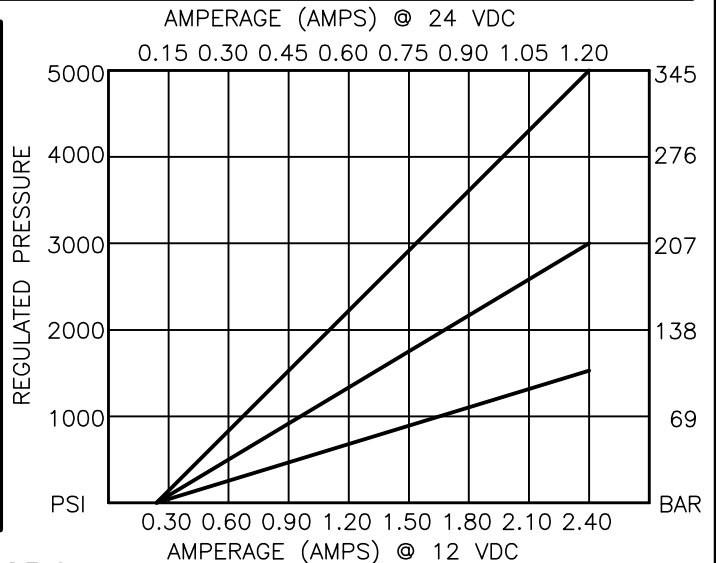

ELECTRO-HYDRAULIC, PROPORTIONAL, PRESSURE REDUCING/RELIEVING VALVE.

DESCRIPTION

This unit is a electro-hydraulic, proportional, screw in cartridge style, pilot operated, sliding spool type, high pressure reducing and relieving control valve.

OPERATIONS

When the coil is de-energized, this valve will allow flow from port 2 to port 1 until pressure in port 1 exceeds the spring bias then the spool will shift and block flow from port 2 to port 1 relieving pressure to port 3. When the coil is energized, the armature moves a precision bias spring against the pilot orifice thus varying the pressure at port 1 (reg.) proportional to the current input regardless of the pressure at port 2. Excess pressure at port 1 is relieved to port 3. When the coil current is increased the pressure will increase and when decreased it will decrease. IN THE EVENT OF POWER FAILURE THE VALVE WILL REDUCE REGULATED PRESSURE AT PORT 1 TO 50 PSI.

FEATURES AND BENEFITS

Continuous-duty, very low heat rise & waterproof solenoid coil.
Pressure in tank port (3) will add to the bias spring setting, and is limited to 2000 PSI.
Interchangeable solenoid coils & terminations options available.
Hardened precision fitted spool & sleeve provides reliable, long life.
A unique self aligning (floating) cage provides very low hysteresis and reliable operation.
Very efficient wet-armature solenoid core tube construction.
All external carbon steel parts are plated for longer life against the elements.
All cartridge valves are 100% functionally tested.

SPECIFICATIONS

OPERATING PRESSURE: 5,000 PSI [350 Bar]
PROOF PRESSURE: 10,000 PSI [700 Bar]
REGULATED PRESSURE: 50 to 5000 PSI [3,5 to 345] See performance chart.
FLOW: 24.0 GPM [91,0 L/M] nominal.
INTERNAL PILOT FLOW: 60 cu.in/min [1,0 l/m] @ 5,000 PSI [350 Bar]
VALVE HOUSINGS: 2500 PSI [175 Bar] = Aluminum - Anodized.
5000 PSI [350 Bar] = Steel - Unplated.
OPERATING TEMPERATURE: -40° to +250° F. [-40° to +120° C.]
OPERATING MEDIA: All general purpose hydraulic fluids such as MIL-H-5606, SAE-#10, SAE-#20, etc.
RESPONSE: The most efficient method to control this valve is with current control and a 50 Hz dither.
POWER REQUIREMENTS: 12 VDC, Operating current 0.2 to 2.4 AMPS.
24 VDC, Operating current 0.1 to 1.2 AMPS.
SEAL KIT: SKN-1231 Buna "N"
SKV-1231 Viton
INSTALLATION: No restrictions.
WEIGHT: 2.3 lb [1,2 kg] cartridge with coil only.
VALVE CAVITY: #C1230, See Page 0-033.0.