

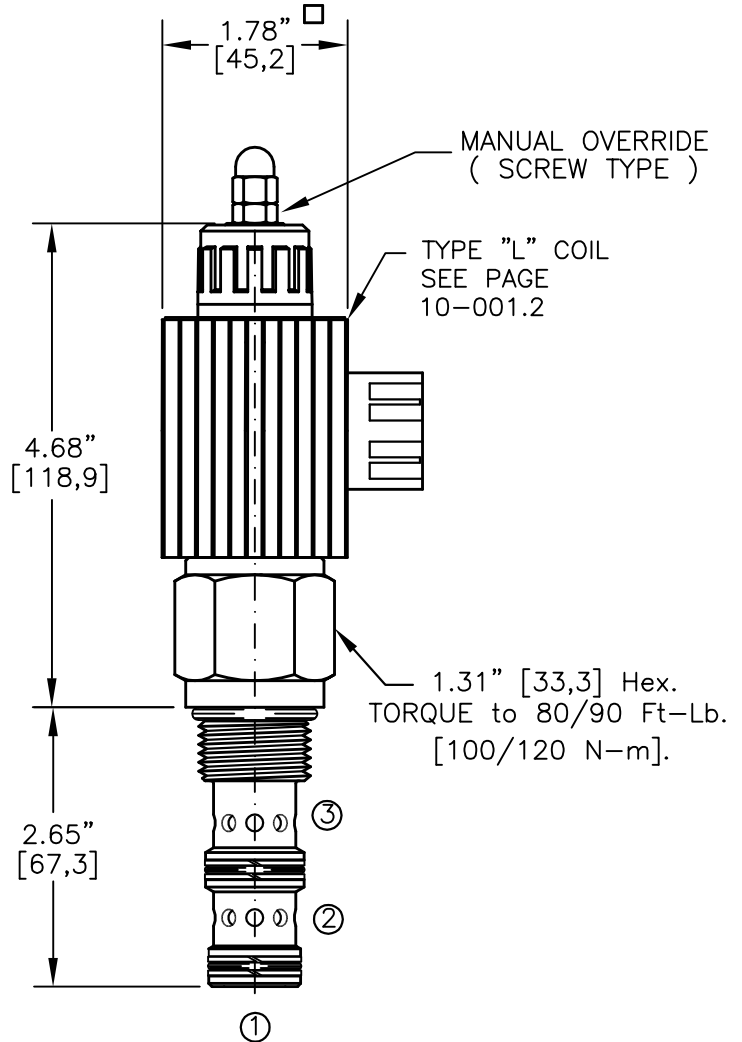

ELECTRO-HYDRAULIC, PROPORTIONAL, PRIORITY, PRESSURE COMP, FLOW CONTROL VALVE.

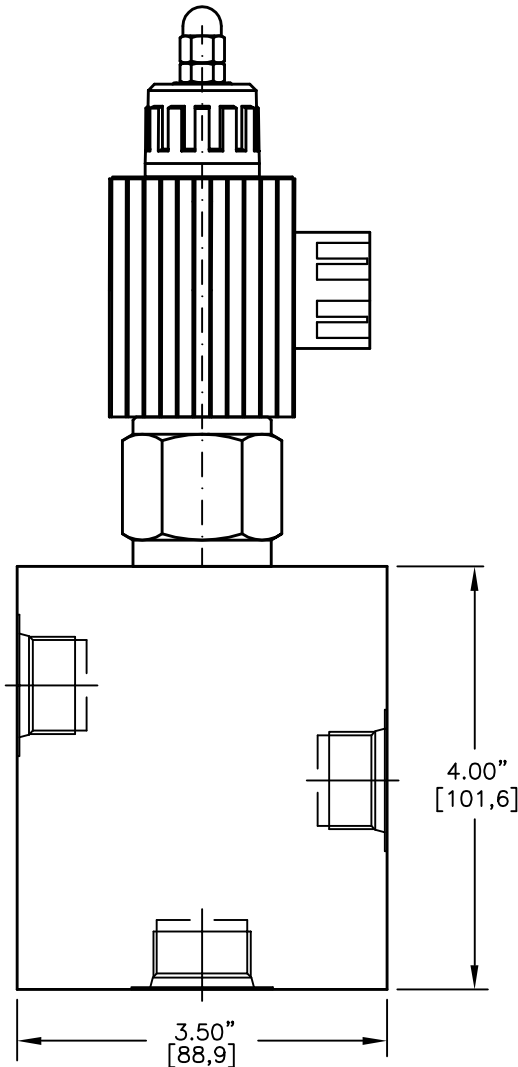
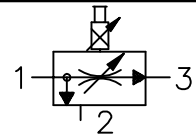

FOR ALUMINUM OR STEEL VALVE HOUSING CONFIGURATIONS SEE PAGE 0-033.1

EPFB-12-X-X-XX-X-X-XXX X

BASIC

SIZE
12 = 1.062"-12UNF

SEALS
N = BUNA "N"
V = VITON

STYLE
C = NORMALLY CLOSED
O = NORMALLY OPEN

REGULATED FLOW
05 = 0 TO 5.0 GPM
10 = 0 TO 10.0 GPM
15 = 0 TO 15.0 GPM

"A" = ALUM. HOUSING
"S" = STEEL HOUSING

TERMINALS
L=18GA. 24" LEADS
T=SPADE TERM.
B=BOLT TERM.
G=DIN43650
W=WEATHER-PACK
D=DEUTSCH-DT04-2P
M=METRI-PACK CONN.

VOLTAGE AMPS
12D = 12 VDC 3.00
24D = 24 VDC 1.50

ADJUSTMENT OPTIONS
0 = NONE
M = MANUAL OVERRIDE

PORTS
0 = CARTRIDGE ONLY
06BX = G 3/4" BSPP
08BX = G 1" BSPP
12TX = SAE - #12
16TX = SAE - #16

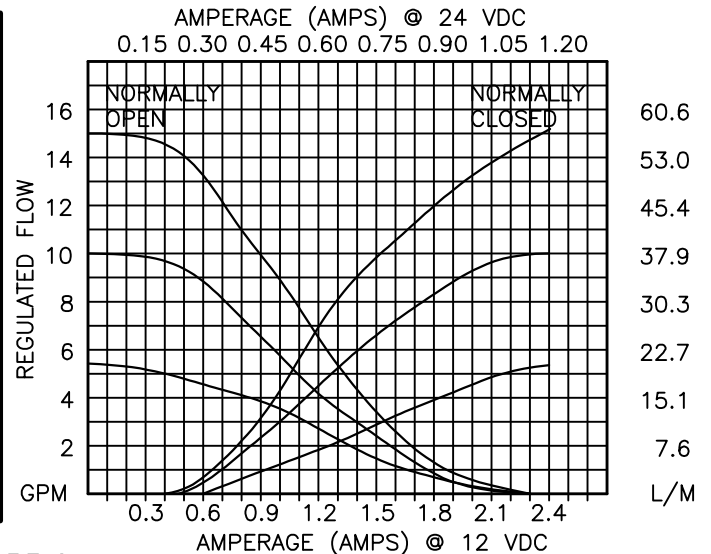



PROPORTIONAL, PRIORITY TYPE, PRESSURE COMP, FLOW CONTROL VALVE.

DESCRIPTION

This valve is a cartridge style, electro-hydraulic, proportional, priority (BY-PASS) type, pressure compensated, hydraulic flow control. Regulated flow 15.0 GPM [56,8 L/M] max. is proportional to the current input regardless of load or system pressure. After the priority flow is satisfied the excess flow is diverted to a secondary circuit or to tank. Maximum inlet flow is 26.0 GPM [98,4 L/M].

OPERATIONS

This unit is a direct acting (NO PILOT FLOW), electro hydraulic, proportional, pressure compensated, flow control valve. When the coil is energized the armature moves the metering orifice open against a precision bias spring varying the flow. A pressure compensator spool (HYDROSTAT) modulates the flow at 100 PSI/6,9 Bar delta "P" providing the valve with a constant regulated flow regardless of load or system pressure. When current is increased to the coil the flow will increase, as the current is decreased the flow will decrease proportionally. IN THE EVENT OF POWER FAILURE THE VALVE WILL CLOSE.

FEATURES AND BENEFITS

Continuous-duty, very low heat rise & waterproof solenoid coil.
Interchangeable solenoid coils & termination options available.
Hardened precision fitted spool & sleeve provides reliable, long life.
Very efficient wet - armature solenoid core tube construction.
All external carbon steel parts are plated for longer life against the elements.
All cartridge valves are 100% functionally tested.

SPECIFICATIONS

OPERATING PRESSURE: 5,000 PSI [350 Bar]
PROOF PRESSURE: 10,000 PSI [700 Bar]
REGULATED FLOW: 15.0 GPM [56,7 l/m] Max. See performance chart.
INTERNAL LEAKAGE: 20 cu.in/min [330 cc/m] @ 5,000 PSI [350 Bar]
VALVE HOUSINGS: 2500 PSI [175 Bar] = Aluminum - Anodized.
5000 PSI [350 Bar] = Steel - Unplated.
OPERATING TEMPERATURE: -40° to +250° F. [-40° to +120° C.]
OPERATING MEDIA: All general purpose hydraulic fluids such as
MIL-H-5606, SAE-#10, SAE-#20, etc.
RESPONSE: The most efficient method to control this valve is with
current control and a 50 Hz dither.
POWER REQUIREMENTS: 12 VDC, Operating current 0.2 to 2.2 AMPS.
24 VDC, Operating current 0.1 to 1.1 AMPS.
SEAL KIT: SKN-1232 Buna "N"
SKV-1232 Viton
INSTALLATION: No restrictions.
WEIGHT: 2.66 lb [1,20 kg] cartridge with coil only.
VALVE CAVITY: #C1230, See Page 0-033.0.