

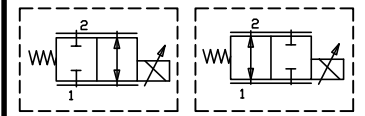

PROPORTIONAL, NORMALLY CLOSED OR NORMALLY OPEN, IN-LINE, NON-COMPENSATED FLOW CONTROL VALVE.

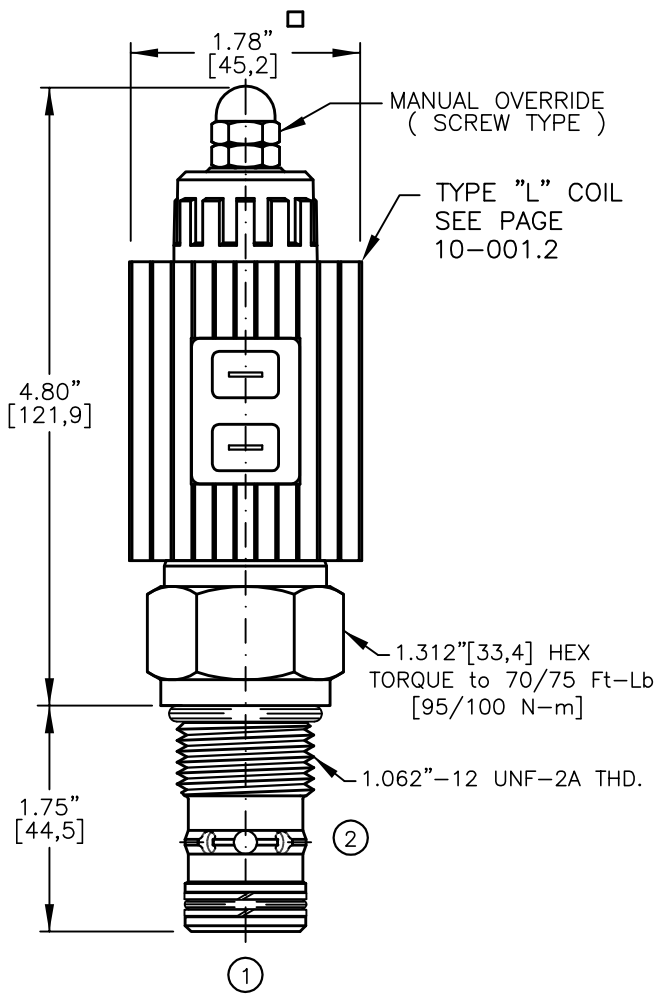

UL approved coil, IP68 and IP69K rated when used with waterproof connector.

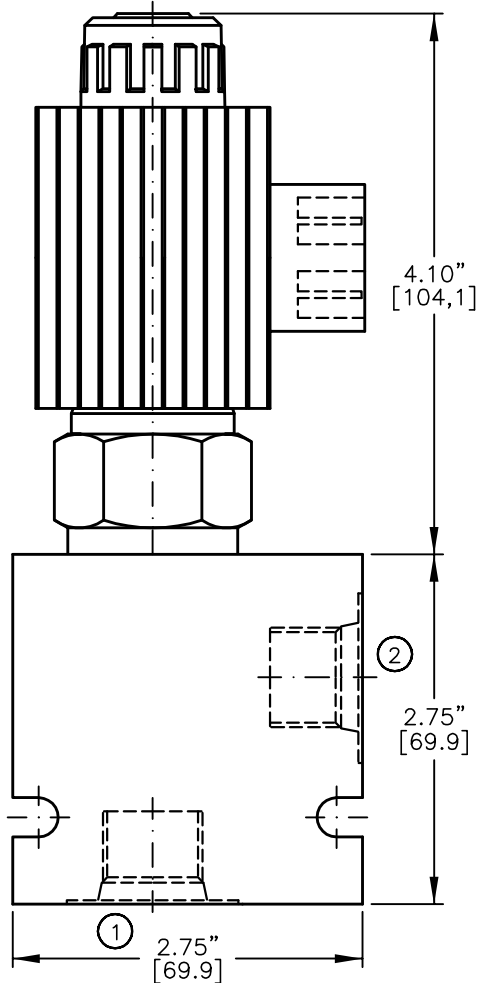

NOTES:

- 1. FOR ALUMINUM OR STEEL VALVE HOUSING CONFIGURATIONS SEE PAGE 0-013.1
- 2. SOLENOIDS AVAILABLE WITH DIODES - CONSULT FACTORY.

**PFCV-12-X-X-XX-X-X-XXX X**

**BASIC**

SIZE  
12 = 1.062"-12UNF

SEALS  
N = BUNA "N"  
V = VITON

STYLE  
C = NORMALLY CLOSED  
O = NORMALLY OPEN

REGULATED FLOW  
06 = 0 TO 6.0 GPM  
12 = 0 TO 12.0 GPM  
18 = 0 TO 18.0 GPM  
24 = 0 TO 24.0 GPM

TERMINALS  
L=18GA. 24" LEADS  
T=SPADE TERM.  
B=BOLT TERM.  
G=DIN43650  
W=WEATHER-PACK  
D=DEUTSCH-DT04-2P  
M=METRI-PACK CONN.

VOLTAGE AMPS  
12D = 12 VDC 3.00  
24D = 24 VDC 1.50

ADJUSTMENT OPTIONS  
O = NONE  
M = MANUAL OVERRIDE

PORTS  
0 = CARTRIDGE ONLY  
04BX = G 1/2" BSPP  
06BX = G 3/4" BSPP  
10TX = SAE - #10  
12TX = SAE - #12

"A" = ALUM. HOUSING  
"S" = STEEL HOUSING

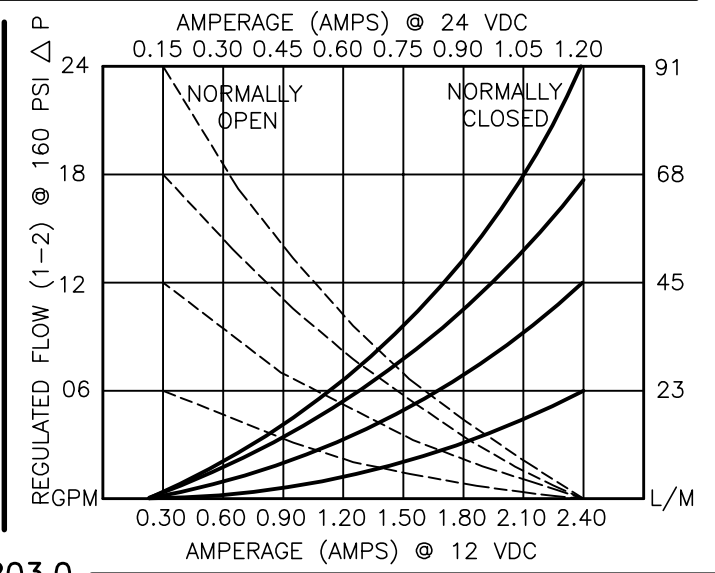

**PROPORTIONAL, IN-LINE TYPE, FLOW CONTROL VALVE.****DESCRIPTION**

This valve is a cartridge style, electro-hydraulic, proportional, in-line (RESTRICTIVE) type, hydraulic non-compensated flow control. Regulated flow Normally Closed 0 to 24.0 GPM [0 to 91,2 L/M] max. Normally Open 24.0 to 0 GPM [91,2 to 0 L/m] @ 160 PSI DELTA P. Flow is proportional to the current input.

**OPERATIONS**

This unit is a direct acting (NO PILOT FLOW), electro-hydraulic, proportional, non-compensated, flow control valve. When the coil is energized the armature moves the metering orifice to open or to closed position against a precision bias spring varying the flow.

When current is increased or decreased to the coil the flow will increase or decrease proportionally.

IN THE EVENT OF POWER FAILURE THE VALVE WILL CLOSE OR OPEN DEPENDING ON THE VALVE VERSION.

**FEATURES AND BENEFITS**

Continuous-duty, very low heat rise & waterproof solenoid coil.

Interchangeable solenoid coils & terminations options available.

Hardened precision fitted spool & sleeve provides reliable, long life.

Very efficient wet - armature solenoid core tube construction.

All external carbon steel parts are plated for longer life against the elements.

All cartridge valves are 100% functionally tested.

**SPECIFICATIONS**

OPERATING PRESSURE: 5,000 PSI [350 Bar]

PROOF PRESSURE: 10,000 PSI [700 Bar]

REGULATED FLOW: 25.0 GPM [91,2 l/m] Max. See performance chart.

INTERNAL LEAKAGE: 30 cu.in/min [495 cc/m] @ 5,000 PSI [350 Bar]

VALVE HOUSINGS: 2500 PSI [175 Bar] = Aluminum - Anodized.

5000 PSI [350 Bar] = Steel - Unplated.

OPERATING TEMPERATURE: -40° to +250° F. [-40° to +120° C.]

OPERATING MEDIA: All general purpose hydraulic fluids such as

MIL-H-5606, SAE-#10, SAE-#20, etc.

RESPONSE: The most efficient method to control this valve is with current control and a 50 Hz dither.

POWER REQUIREMENTS: 12 VDC, Operating current 0.4 to 2.4 AMPS.

24 VDC, Operating current 0.2 to 1.2 AMPS.

SEAL KIT: SKN-1222 Buna "N"

SKV-1222 Viton

INSTALLATION: Use undercuts in cavity to obtain max rated flow when using a pressure compensator in series.

WEIGHT: 0.84 lbs [0,38 kg] cartridge only.

1.09 lbs [0,50 kg] coil & housing.

1.10 lbs [0,50 kg] aluminum body.

4.20 lbs [1,90 kg] steel body.

VALVE CAVITY: #C1220, See Page 0-013.0.