

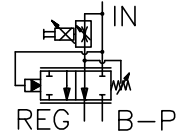

PRESSURE COMPENSATED, NORMALLY CLOSED OR NORMALLY OPEN PROPORTIONAL, PRIORITY FLOW CONTROL VALVE.



UL approved coil, IP68 and IP69K rated when used with waterproof connector.

LIMITED RANGE ADJUSTMENT (SCREW TYPE)

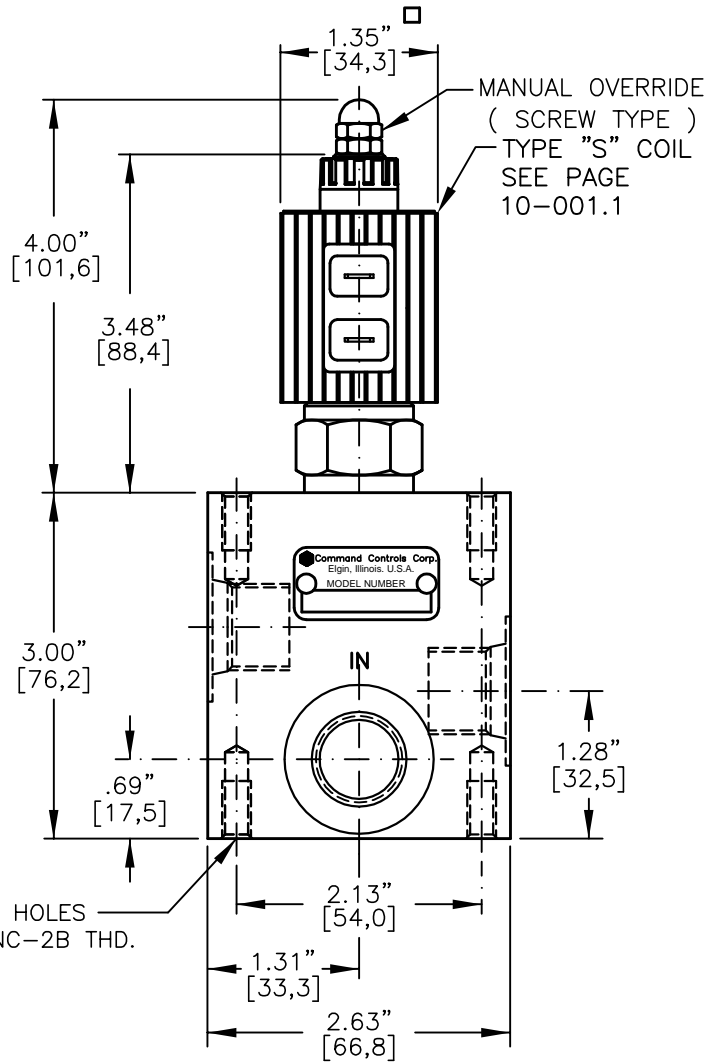
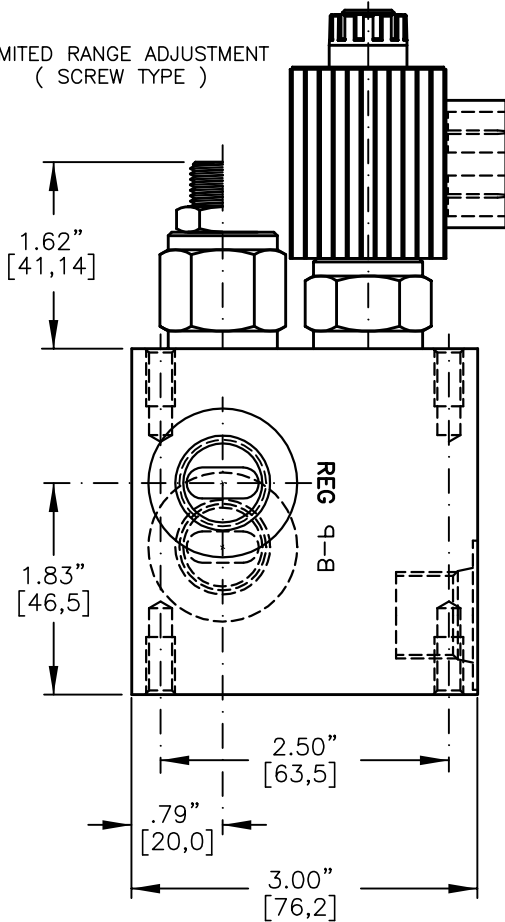

4 MOUNTING HOLES 1/4"-20 UNC-2B THD. BOTH ENDS

NOTES:

1. SOLENOIDS AVAILABLE WITH DIODES - CONSULT FACTORY.

PBFC-08-X-X-XX-X-X-X-XXX-XXX X

BASIC _____

SIZE _____
08 = 3/4"-16UNF

SEALS _____
N = BUNA "N"
V = VITON

STYLE _____
C = NORMALLY CLOSED
O = NORMALLY OPEN

REGULATED FLOW _____
03 = 0 TO 2.5 GPM
04 = 0 TO 3.8 GPM
05 = 0 TO 5.0 GPM

TERMINALS _____
L=18GA. 24" LEADS
T=SPADE TERM.
B=BOLT TERM.
G=DIN43650
W=WEATHER-PACK
D=DEUTSCH-DT04-2P
M=METRI-PACK CONN.

VOLTAGE AMPS
12D = 12 VDC 1.80
24D = 24 VDC 0.90

ADJUSTMENT OPTIONS
O-F-100 = NONE
M-F-100 = MANUAL OVERRIDE
O-S-160 = LIMITED RANGE ADJ.
M-S-160 = BOTH MO/LTD ADJ.

PORTS
08TX = SAE - #8
"A" = ALUM. HOUSING
"S" = STEEL HOUSING

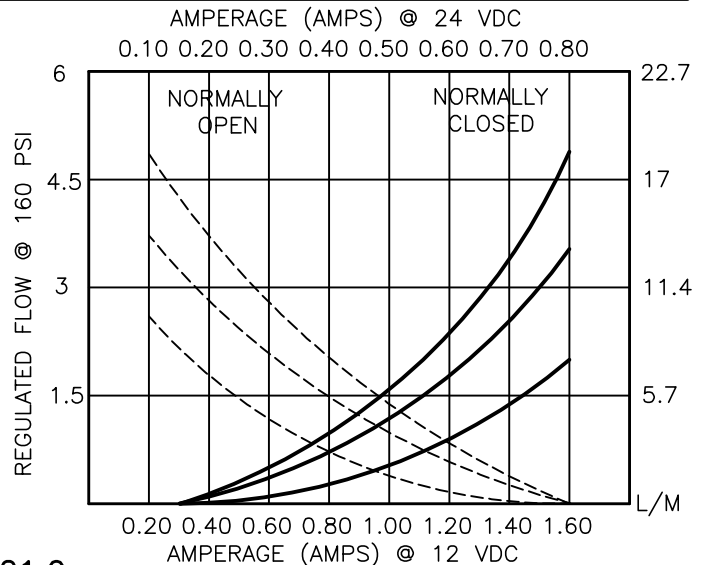

**PRESSURE COMPENSATED, PROPORTIONAL, PRIORITY FLOW CONTROL VALVE.****DESCRIPTION**

This valve is an electro-hydraulic, proportional, priority (By-Pass) type, pressure compensated, hydraulic flow control. Regulated flow normally closed 0 to 5.0 GPM [0 to 19,0 L/M] or normally open 5.0 to 0 GPM [19,0 to 0 L/M] @ 160 PSI DELTA P. is proportional to the current input regardless of load or system pressure. After the priority flow is satisfied the excess flow is diverted to a secondary circuit or to tank. Maximum inlet flow is 10.0 GPM [38,0 L/M].

OPERATIONS

This unit is a direct acting (NO PILOT FLOW), electro-hydraulic, proportional, pressure compensated, flow control valve. When the coil is energized the armature moves the metering orifice open or closed against a precision bias spring varying the flow. A pressure compensator spool (HYDROSTAT) modulates the flow at 160 PSI/11,0 Bar delta "P" providing pressure. When current is increased or decreased to the coil; the flow will increase or decrease proportionally.

IN THE EVENT OF POWER FAILURE THE VALVE WILL CLOSE OR OPEN RESPECTIVELY.

FEATURES AND BENEFITS

Continuous-duty, very low heat rise & waterproof solenoid coil.
Interchangeable solenoid coils & terminations options available.
Hardened precision fitted spool & sleeve provides reliable, long life.
Very efficient wet - armature solenoid core tube construction.
All external carbon steel parts are plated for longer life against the elements.
All valves are 100% functionally tested.

SPECIFICATIONS

OPERATING PRESSURE: 5,000 PSI [350 Bar]

PROOF PRESSURE: 10,000 PSI [700 Bar]

REGULATED FLOW: 5.0 GPM [19 l/m] Max. See performance chart.

INTERNAL LEAKAGE: 23 cu.in/min [377 cc/m] @ 5,000 PSI [350 Bar]

VALVE HOUSINGS: 2500 PSI [175 Bar] = Aluminum - Anodized.

5000 PSI [350 Bar] = Steel - Unplated.

OPERATING TEMPERATURE: -40° to +250° F. [-40° to +120° C.]

OPERATING MEDIA: All general purpose hydraulic fluids such as
MIL-H-5606, SAE-#10, SAE-#20, etc.

RESPONSE: The most efficient method to control this valve is with
current control and a 50 Hz dither.

POWER REQUIREMENTS: 12 VDC, Operating current 0.4 to 1.8 AMPS.

24 VDC, Operating current 0.2 to 0.9 AMPS.

SEAL KIT: Buna "N": SKN-0822, SKN-0842

VITON: SKV-0822, SKV-0842

INSTALLATION: No restrictions.

WEIGHT: 4.98 lbs [2,26 kg]. aluminum body.

8.25 lbs [3,76 kg]. steel body.